

# EPIC® Pin & Sleeve Connectors

EPIC®

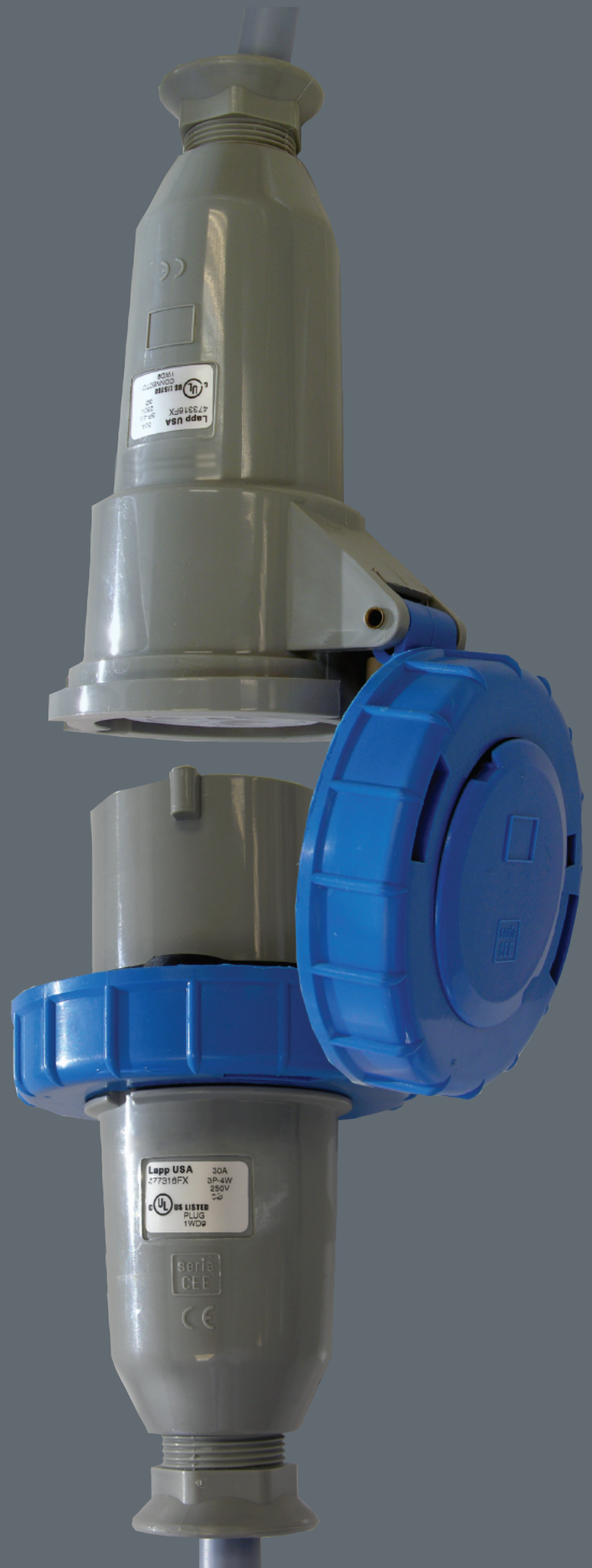

15



# EPIC® Pin & Sleeve Connectors

Global Power Connectors for the North American & International Market

## PIN & SLEEVE OVERVIEW

Overview of Male Plugs & Inlets	447
Overview of Female Connectors & Switched Interlocked Socket Outlets	448
Construction of Connectors	450
MULTIMAX Connector Overview	452
ULYSSE Switched Socket Outlets	454
ALUPRES Switched Socket Outlets	455

<b>North American Standards: Selection Charts</b>	<b>456</b>
---	------------

<b>International Standards: Selection Charts</b>	<b>458</b>
--	------------

## DIMENSIONAL DATA

<b>North American 20 Amp/ International 16 Amp</b>	
• Male Plugs & Female Connectors	461
• Female Connectors & Receptacles	462
• Male Plug Inlets & Switched Socket Outlet	463
<b>North American 30 Amp/ International 32 Amp</b>	
• Male Plugs & Female Connectors	464
• Female Panel Mount Receptacles	465
• Male Plug Inlets & Switched Socket Outlet	466
<b>North American 60 Amp/ International 63 Amp</b>	
• Male Plugs, Female Connectors, & Female Receptacles	467
• Male Plug Inlets & Switch Socket Outlets	468
<b>North American 100 Amp/ International 125 Amp</b>	
• Male Plug, Female Connectors, & Female Receptacles	469
• Male Plug Inlets	470
<b>Accessories</b>	<b>470</b>

## TECHNICAL DATA

IEC & UL Standards	472
Ground Pin Locations & Voltage	473
Key Features	474
Test Data	475
Cable OD Accommodation	475
Wire Size Accommodation	476
Construction Materials	476
Plugs & Connectors Reference Data	477
Switch Socket Outlet Reference Data	478
Circuit Wiring Diagrams	479

# EPIC® Pin & Sleeve Connectors

EPIC® Pin & Sleeve Connectors are designed to meet the power connectivity needs and requirements of your business. Whether you are designing machinery for that important international customer, specifying mobile power solutions on the factory floor, or planning outdoor power distribution systems, EPIC® Pin & Sleeve Connectors and interlocked Switched Socket Outlets can provide a safe, cost-effective solution for your industrial wiring requirements.

UL Approved North American devices are available for 20, 30, 60 and 100 amps. International rated devices are available for 16, 32, 63 and 125 amps. Both North American and International devices are

available in splashproof (IP44) and watertight (IP67) configurations.

EPIC® Pin & Sleeve Connectors conform to IEC 60309-1 and -2 standards, however advanced industrial patented design has led to a range of superior products. For example, the MULTIMAX pin and sleeve connectors have a unique patented design that can be assembled in under 20 seconds thus saving money through reduced downtime and installation savings; they are also a sensible alternative to twist lock connectors in many applications.

The revolutionary fully patented ULYSSE range of interlocked switched socket outlets offers several unique features:

- It comes prewired thus saving time and money.
- It has been tested and rated to both IP 66 and IP 67 providing an environmental seal from high pressure jets of water and temporary immersion.
- Disconnect rated Cam switches allow direct switching of induction motor loads.
- Safety interlocks prevent power from being turned on unless a plug has been inserted in the outlet; the plug from being removed as long as power is turned on; prevents the interior of the enclosure from being accessed while the device is energized.
- Double insulation eliminates electrical paths from the inside of the enclosure to the exterior.
- Tough, reinforced thermoset plastic enclosure passes 960°C glow wire test. Provides outstanding resistance to extremes of heat and chemical agents.

As you would expect from a quality approved vendor (Lapp is ISO 9001-2000 certified) all North American products carry the  mark and are certified for use in the US and Canada in accordance with UL 1682 & UL1686 standards and CSA standard C22.2

No. 182.1-02. The recognized UL file number for EPIC® Pin & Sleeve connectors is E223777. All products comply with IEC 60309-1, -2 and carry the CE Mark.

## VARIETY OF INDUSTRIES SERVICED



Automotive  
Building Electrical Supply  
Outdoor Power Distribution  
Applications Chemical Industry  
Food Processing Equipment  
Motors  
Portable Equipment  
Scientific/ Photographic Labs  
Small Workshops  
Steel & Heavy Industry  
Wine & Beer Production



# EPIC® Pin & Sleeve Connectors

## Overview of Male Plugs & Inlets

### EPIC® MULTIMAX Series Plugs:

#### Protected Straight Plugs with Rapid Wiring

IP 44

**Characteristics:** Patented click-lock housing eliminates assembly screws and speeds assembly. Patented self-locking cable grip is vibration proof and eliminates external stress to the cable seal and contact terminals. Available in 20 & 30 amp North American configurations and 16 & 32 amp International versions.

**Uses:** Indoor: cable-to-cable connections, cable-to-power outlet connection.



### EPIC® CEE Series Plugs:

#### High Performance Protected Straight Plugs

IP 44

**Characteristics:** Nickel plated and rounded pins for easy insertion; non-slip grip, cable entry with screw-in type cable gland, internal saddle-clamp strain relief, very thick and self-extinguishing body and grip. Available in 20 & 30 amp North American configurations and 16 & 32 amp International versions.

**Uses:** Indoor: cable-to-cable connections, cable to power outlet connection



### EPIC® CEE Series Plugs:

#### High Performance Watertight Straight Plugs

IP 67

**Characteristics:** Nickel plated and rounded pins for easy insertion; non-slip grip, cable entry with screw-in type cable gland, internal saddle-clamp strain relief, very thick and self-extinguishing body and grip, gasketed locking ring for water-tight connection.

**Uses:** Indoor wash-down/corrosive and heavy dust atmosphere and outdoor locations; cable-to-cable connections, cable-to-power outlet connection



### EPIC® CEE Series Plugs:

#### High Performance 90° Angled Protected Plugs

IP 44

**Characteristics:** Nickel plated and rounded pins for easy insertion; cable entry with screw-in type cable gland; internal saddle clamp strain relief; very thick and self-extinguishing body and grip. Available in 20 amp North American configurations and 16 amp International versions.

**Uses:** Indoor: cable-to-power outlet connection



### EPIC® CEE Series Plugs:

#### High Performance 90° Angled Watertight Plugs

IP 67

**Characteristics:** Nickel plated and rounded pins for easy insertion; cable entry with screw-in type cable gland, internal saddle-clamp strain relief; very thick and self-extinguishing body and grip; gasketed locking ring for water-tight connection. Available in 20 amp North American configurations and 16 amp International uses.

**Uses:** Indoor wash-down/corrosive and heavy dust atmosphere and outdoor locations; cable-to-power outlet connection



### EPIC® CEE Series Inlets:

#### 90° Angled Protected Wall Mounting Appliance Inlets

IP 44

**Characteristics:** Suitable for both wall mounting and mounting on machines; smooth upper wall for drilling cable entry hole; very thick and self-extinguishing plug body and case. Available in 20 & 30 amp North American configurations and 16 & 32 amp International versions.

**Uses:** Indoor: Equipment-to-cable connector



### EPIC® CEE Series Inlets:

#### 90° Angled Watertight Wall Mounting Appliance Inlets

IP 67

**Characteristics:** Suitable for both wall mounting and mounting on machines; smooth upper wall for drilling cable entry hole; very thick and self-extinguishing plug body and case; gasketed locking ring for water-tight connection. Available in 20 & 30 amp North American configurations and 16 & 32 International versions.

**Uses:** Indoor wash-down/corrosive and heavy dust atmosphere and outdoor locations; equipment-to-cable connector



### EPIC® CEE Series Inlets:

#### High Performance Watertight Straight Flush Mounting Appliance Inlets

IP 67

**Characteristics:** Nickel plated and round pins for easy insertion; contact holder insert in thermoset plastic; very thick and self-extinguishing plug body; gasketed locking ring for water-tight connection. Available in 60 & 100 amp North American configurations and 63 & 125 amp International versions.

**Uses:** Indoor wash-down/corrosive and heavy dust atmosphere and outdoor locations; equipment-to-cable connector



# EPIC® Pin & Sleeve Connectors

## Overview of Female Connectors, Female Receptacles & Switch Interlocked Socket Outlets

### EPIC® MULTIMAX Series Female Connectors:

#### Protected Straight Connectors with Rapid Wiring

IP 44

**Characteristics:** Patented click-lock housing eliminated assembly screws and speeds assembly. Patented self-locking cable grip is vibration proof and eliminates external stress to the cable seal and contact terminals. Available in 20 & 30 amp North American configurations and 16 & 32 amp International versions.

**Uses:** Indoor: cable-to-cable connections, cable-to-equipment inlet connection



### EPIC® CEE Series Female Connectors:

#### High Performance Watertight Straight Connectors

IP 67

**Characteristics:** Rounded, solid-brass socket contacts for easy insertion; very thick and self-extinguishing body and non-slip grip; cable entry with screw-in type cable gland, internal saddle-clamp strain relief, gasketed locking ring for water-tight connection.

**Uses:** Indoor wash-down/corrosive and heavy dust atmosphere and outdoor locations: cable-to-cable connections, cable-to-equipment inlet connection



### EPIC® CEE Series Panel Mounted Receptacles:

#### Straight Flush Mounting Protected Socket Outlets

IP 44

**Characteristics:** Rounded, solid brass socket contacts for easy insertion; very thick and self-extinguishing body and cover. Gaskets are made of non-aging elastomer. Available in 20 & 30 amp North American configurations and 16 & 32 amp International versions.

**Uses:** Indoor: Fixed power source-to-cable plug connection



### EPIC® CEE Series Panel Mounted Receptacles:

#### Watertight Angled Flush Mounting Socket Outlets

IP 67

**Characteristics:** Rounded, solid brass socket contacts for easy insertion. Very thick and self-extinguishing body and cover. Gaskets are made of non-aging elastomer, gasketed locking ring for water-tight connection.

**Uses:** Indoor wash-down/corrosive and heavy dust atmosphere and outdoor locations; Fixed power source-to-cable plug connection



### EPIC® CEE Series Panel Mounted Receptacles:

#### 90° Angled Wall Mounting Protected Socket Outlets

IP 44

**Characteristics:** Suitable for both wall mounting and mounting on machines; outer cable entry through screw type cable gland, very thick and self-extinguishing body and cover, rounded solid-brass socket contacts for easy insertion. Available in 20 & 30 amp North American configurations and 16 & 32 amp International versions.

**Uses:** Indoor: Fixed power source-to-cable plug connection



### EPIC® ULYSSE Series Switch Interlocked Socket-Outlets:

#### Wall Mounting Interlocked Socket-Outlets with Fuse Holder Base

IP 66 & 67

**Characteristics:** Heavy duty modular enclosure of reinforced thermoset plastic for superior strength and heat and chemical resistance; dual environmental rating IP 66 (high pressure water jets) and IP 67 (accidental immersion); heavy-duty disconnect rated switch for direct switching of motor loads; safety interlocked so power cannot be turned on unless a plug is inserted, plug cannot be removed unless power is switched off. Available in 20, 30, & 60 amp North American configurations and 16, 32, & 63 amp International versions.

**Uses:** Indoor wash-down/corrosive and heavy dust atmosphere and outdoor locations; Fixed power source disconnect-to-cable plug connection.



### EPIC® ALUPRES Series Switch Interlocked Socket Outlets:

#### Wall Mounting Interlocked Socket-Outlets in Aluminum Alloy

IP 65/ IP55

**Characteristics:** Heavy-duty modular enclosure of aluminum alloy for superior strength and heat resistance; environmental rating IP 65 (dust-proof and water jets) for 20 & 30 amp outlets (16 & 32 amp International) and IP 55 (dust-tight and water jets) for 60 amp outlets (63 amp International); heavy-duty disconnect rated switch for direct switching of motor loads; safety interlocked so power cannot be turned on unless a plug is inserted, plug cannot be removed unless power is switched off.

**Uses:** Indoor wash-down and abrasive dust atmosphere and outdoor locations; Fixed power source disconnect-to-cable plug connection.



# EPIC® Pin & Sleeve Connectors

## Construction of Connectors

### MULTIMAX Connectors

Spring loaded cover automatically protects against dirt and splashed water when connector is not engaged. Color-coding identifies voltage.

Contact carrier protects recessed contacts and orients the ground contact position based on voltage rating. Prevents connector mis-mating.

High copper solid brass, self adjusting contacts provide easy insertion/withdrawal and minimizes heat buildup.

Longer ground contact assures first-make, last break connection

Patented click-lock housing locks and unlocks in 1/16th turn eliminating assembly screws and speeding assembly.

Contact terminal screws all face the same direction to simplify wiring.

Patented self-locking cable grip is vibration proof and prevents accidental loosening.

4-finger cable grip secures cable, prevents pullout, and eliminates strain on contact terminals.

Patented universal neoprene membrane seal accommodates a wide range of cable diameters and cable surface irregularities. Seals out dirt, splashed water, and contaminants.

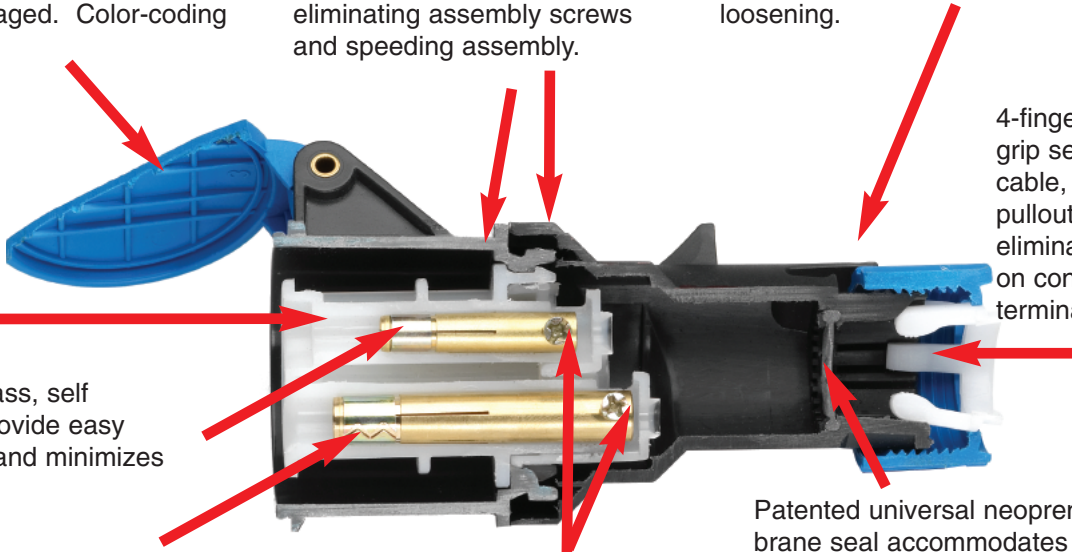

### CEE IP 44 Connectors

High-impact, non-conductive thermoplastic housing enhances electrical safety and provides excellent chemical resistance.

Retaining tab engages with mating connector's cover to prevent unintentional withdrawal.

CEE male contacts are nickel plated, high copper solid brass, for easy insertion/withdrawal, improved chemical resistance, and minimum heat buildup.

Ribbed body provides secure hand grip.

Threaded cable gland protects cable jacket and accepts a variety of optional SKINTOP® strain reliefs and cable glands.

Neoprene onion skin grommet accommodates a wide range of cable diameters. Seals out dirt, and contaminants and is water-tight.

Internal, saddle type cable clamp secures cable, prevents pullout, and eliminates strain on contact terminals.

Molded housing keyway aligns mating devices and prevents connector mismatching.

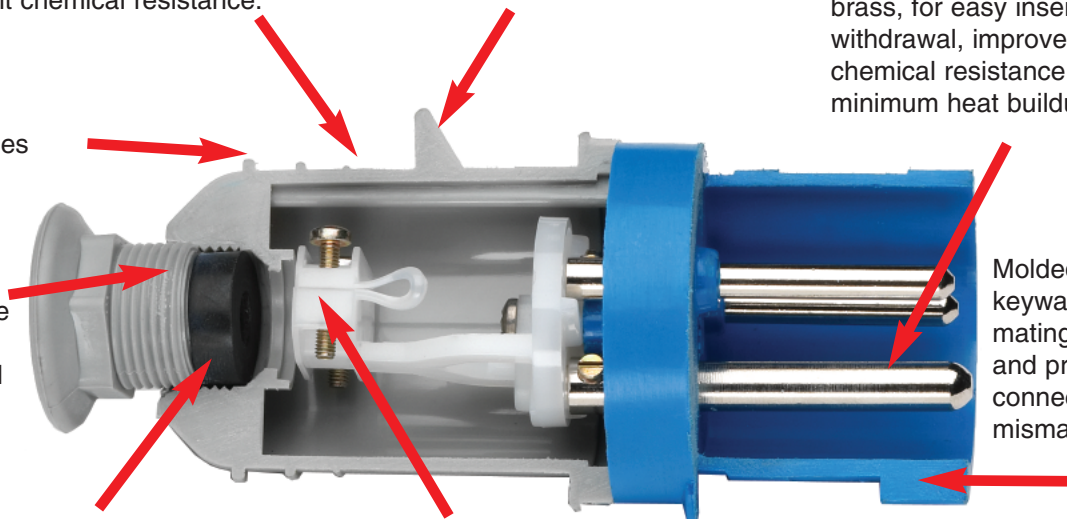

# EPIC® Pin & Sleeve Connectors

## Construction of Connectors

### CEE IP 67 Connectors

Contact carrier protects recessed contacts and orients the ground contact position based on voltage rating. Prevents connector mis-mating. Use of thermoset plastic above 60 amps provides increased flame and arcing resistance in high-current, high-temperature applications.

Spring loaded, gasketed, locking cover automatically protects against dirt and water when connector is not engaged. Color coding identifies voltage.

High copper solid brass, self adjusting contacts provide easy insertion/withdrawal and minimizes heat build up.

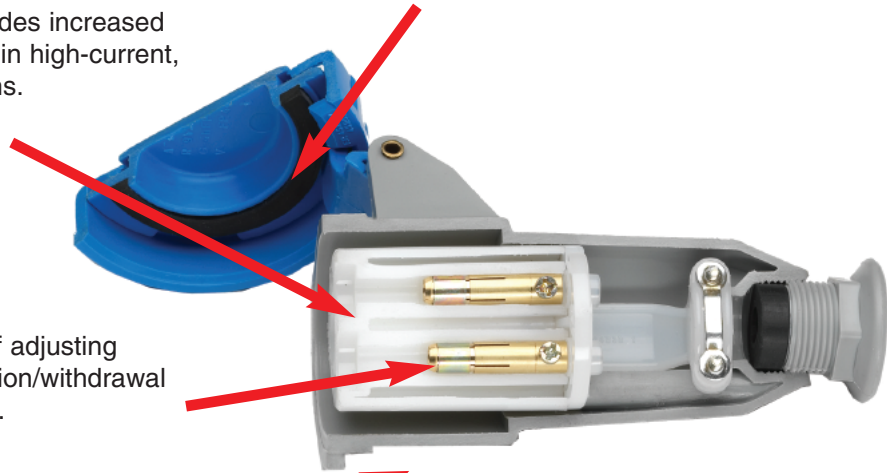

Molded housing keyway aligns mating devices and prevents connector mismating.

### CEE IP 67 Plugs

High impact, non-conductive thermoplastic housing enhances electrical safety and provides excellent chemical resistance.

Retaining tab engages with mating connector's cover to prevent unintentional withdrawal.

CEE male contacts are nickel plated, high copper solid brass, for easy insertion/ withdrawal, improved chemical resistance, and minimum heat buildup.

Ribbed body provides secure hand grip.

Threaded cable gland protects cable jacket and accepts a variety of optional SKINTOP® strain relief and cable glands.

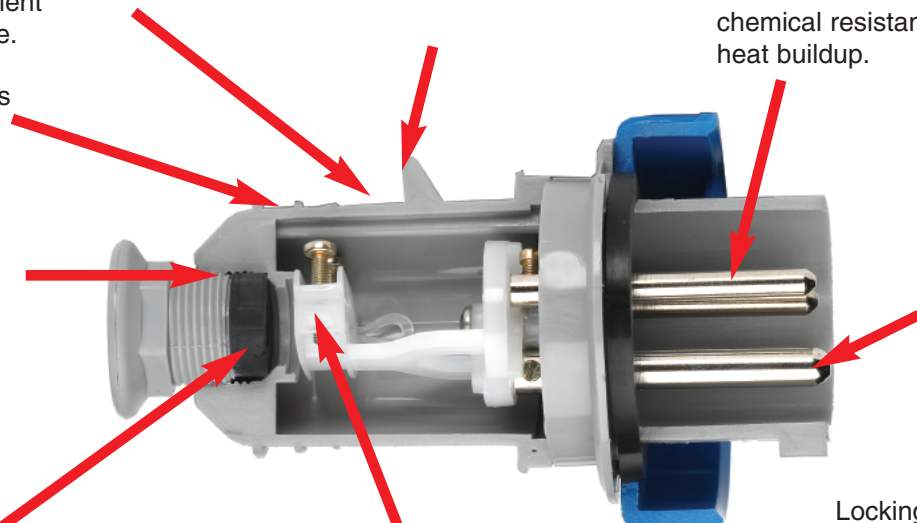

Longer ground contact assures first-make, last break connection.

Neoprene onion skin grommet accommodates a wide range of cable diameters. Seals out dirt, and contaminants and is water-tight.

Internal, saddle type cable clamp secures cable, prevents pullout, and eliminates strain on contact terminals.

Locking ring and gasket provide IP 67 water-tight seal when mated with connector.

# EPIC® Pin & Sleeve Connectors

MULTIMAX Connectors can be assembled in 20 seconds

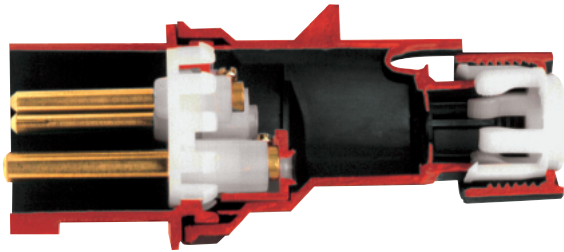

**1. SNAPLOCK FUNCTION PROVIDES SPEED IN ASSEMBLING**  
The grip is assembled without any tools, with a 1/16 turn.

**2. GUARANTEE OF CABLE CLAMPING OVER TIME.**  
The cord grip with the shade ring locking device prevents accidental loosening of the cable.

**3. SAFETY OF PROTECTION RATING EVEN WITH THE CABLE STRESSED.**  
The radial clamping cord grip is located external to the universal membrane seal. The un-stressed seal maintains its environmental rating throughout the connector's service life.

## 4 Easy Steps to Assemble



### HIGH QUALITY

Made with first-rate thermoplastic, these products are composed of an insulating enclosure with a quality finish. The reinforced walls make the products extremely robust and impact resistant. The UV stabilized technopolymers ensure resistance against exposure to direct sunlight.

**1** Insert the prepared cable into the grip.

**2** Tighten the terminal screws which are unscrewed in advance and positioned on the same side.



**3** Close the grip until it clicks. (1/16 turn)

**4** Lock the cable by turning the shade ring until it is locked in position.



# EPIC® Pin & Sleeve Connectors

Mating the Connectors

## Male Plugs



## Female Connectors



## Female Panel Mounted Receptacles



## Male Plug Inlets

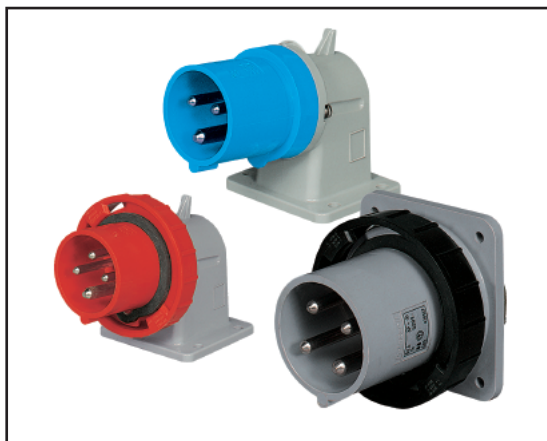

## Switched Socket Outlets with Mechanical Interlock



# EPIC® Pin & Sleeve Connectors

## ULYSSE Series: High Performance Switched Socket Outlets with Mechanical Interlock

The ULYSSE Series interlocked, switched socket-outlets are ideal for indoor and outdoor power service On/Off control. The range consists of North American: 20 amp, 30 amp, and 60 amp models; and International: 16 amp, 32 amp, and 63 amp models. These interlocked outlets can be used individually and mounted using the integral mounting feet, or as part of a multiple unit distribution board assembly utilizing a patented “quick-mount” support plate and a selection of wire connection junction boxes. The rugged, double insulated thermoset plastic enclosure,

internal fuse holder, and zinc-plated steel interlocking mechanism contribute to long-term operator safety. The rotary switches used in the ULYSSE Series socket-outlets are AC23A-AC3 category devices suitable for direct switching of motor and other highly inductive electrical loads and have a conditional short circuit rating of 10,000 amps. The ULYSSE range meets or exceeds compliance with the following standards: CEI EN 60309, CEI EN 60947, CEI EN 60529, CEI EN 60742, IEC 60309, IEC 947, IEC 529, IEC 742, UL 1682, UL 1686, and UL 508.

### SAFETY

Made of reinforced, thermoset plastic, these products are ideal for outdoor applications. Their rugged industrial design ensures high impact resistance (20 joules) at low and high temperature extremes, electrical insulation, outstanding resistance to extremes of heat and fire (960°C Glow Wire Test; self-extinguishing UL94:V0), as well as resistance to chemical agents, humidity, the prolonged action of UV rays, and atmospheric agents.



### APPLICATIONS:

Manufacturing facilities, food processing, breweries and distilleries, amusement parks, marinas, ski facilities, machine power distribution, and boiler room locations.

### KEY FEATURES

#### Quick & Easy Installation

Used individually, surface mounting is quickly accomplished using the four integral mounting feet. A patented, quick-mount support plate (option) allows multiple units to be assembled into a distribution panel. The switched-outlets can be mounted to the plate using one hand and quickly secured using only two screws. All socket-outlets are provided pre-wired with peeled and numbered cables 70cm long, eliminating the need to open the enclosure. This reduces installation time by 30%.

#### Thermoset Plastic Enclosure

The use of reinforced thermoset plastic ensures the highest possible dimensional stability and resistance to heat, chemical, and mechanical stress. These performance characteristics exceed those of typical switched-outlets constructed using standard thermoplastics. Double-insulation design ensures no electrical path exists from internal components to the outside of the enclosure.

#### Double Environmental Protection (Watertight)

All ULYSSE switched-outlets carry both IP66 and IP67 protection ratings for watertight service against violent water jets as well as accidental immersion.

#### Mechanical Interlock

Zinc-plated steel interlock mechanism guarantees electrical operation only when a plug is inserted in the outlet. Robust design prevents interlock failure even when forced.

#### Ergonomic Control With Lockout

The unique semi-spherical control knob is easily operated even with a gloved hand. To prevent unauthorized operation, the knob can be padlocked in either the “On” or “Off” position.

#### Direct Motor Control

Use of AC23A-AC3 category cam switches allow direct switching of motor and other highly inductive electrical loads and have a conditional short circuit rating of 10,000 amps.

# EPIC® Pin & Sleeve Connectors

## ALUPRES Series: High Performance Switched Socket Outlets with Mechanical Interlock

The ALUPRES Series interlocked, switched socket-outlets are ideal for indoor and outdoor power service On/Off control. The range consists of North American: 20 amp, 30 amp, and 60 amp models; and International: 16 amp, 32 amp, and 63 amp models. These interlocked outlets can be used individually and mounted using the integral mounting tabs, or as part of a multiple unit distribution board assembly. The rugged, aluminum alloy enclosure and zinc-plated steel interlocking mechanism contribute to

long service life and long-term operator safety. The rotary switches used in the ALUPRES Series socket-outlets are AC23A-AC3 category devices suitable for direct switching of motor and other highly inductive electrical loads and have a conditional short circuit rating of 10,000 amps. The ALUPRES range complies with the following standards: CEI EN 60309, CEI EN 60947, CEI EN 60529, CEI EN 60742, IEC 60309, IEC 947, IEC 529, IEC 742, UL 1682, UL1686 and UL 508.

### KEY FEATURES

#### Quick & Easy Installation

Used individually, surface mounting is quickly accomplished using the four integral mounting tabs. An optional support plate allows multiple units to be assembled into a distribution panel.

#### Rugged Aluminum Alloy Enclosure

The powder painted aluminum alloy enclosure provides excellent resistance to heat and corrosive agents. Resistance to impact and mechanical stress is over 50% greater than those of typical switched-outlets constructed using standard thermoplastics.

#### Environmentally Protected (Watertight)

ALUPRES switched-outlets (20/16A & 30/32A) are IP65 rated for watertight service against violent water jets, and (60/63A) are IP 55 rated for watertight service in lower pressure wash-down applications.

#### Mechanical Interlock

Zinc-plated steel interlock mechanism guarantees electrical operation only when a plug is inserted in the outlet. Robust design prevents interlock failure even when forced.

#### Direct Motor Control

Use of AC23A-AC3 category cam switches allow direct switching of motor and other highly inductive electrical loads and have a conditional short circuit rating of 10,000 amps.

#### Motor Power in Kilowatts

Phase	Voltage	Current (amps)		
		20/16	30/32	60/63
3	230/220	4.5 kW	8.5 kW	18 kW
	380/380	7.5 kW	15 kW	31 kW
	460/500	10 kW	17 kW	40 kW
1	230/220	2.8 kW	5 kW	---

#### THE TOUGH ONE

Made of die-cast aluminum alloy, these products are powder painted with polymerized, non-scratch paint at 180°C which makes them ideally suited for abrasive environments. Their rugged industrial design ensures high impact resistance (30 joules) at low and high temperature extremes, and outstanding resistance to extremes of heat and fire. A special chrome treatment applied prior to painting insures protection from corrosion.



#### APPLICATIONS:

Steelworks, foundries, rolling mills, tunnels, and abrasive areas by metal removal machinery and carpentry machines.

# EPIC® Pin & Sleeve Connectors



## Selection Chart: North American Standards

Dimensional Drawings Page 461				Male Plugs				
				IP 67	IP 44	IP 44	IP 67	IP 44
<b>20A</b>	# of Wires	# of Poles	Ground-Clock Position	Part #	Part #	Part #	Part #	Part #
125	3	1+N+PE	4	477203FX	700124FX	477202FX	475203FX	475202FX
250	3	2+PE	6	477303FX	700126FX	477302FX	475303FX	475302FX
480	3	2+PE	7	477273FX	700127FX	477502FX	NA	NA
125/250	4	2+N+PE	12	477833FX	701132FX	477832FX	475833FX	475832FX
3Ø250	4	3+PE	9	477313FX	700139FX	477312FX	475313FX	475312FX
3Ø 480	4	3+PE	7	477513FX	700137FX	477512FX	475513FX	475512FX
3Ø 600	4	3+PE	5	NA	700135FX	NA	NA	NA
3ØY 120/208	5	3+N+PE	9	477323FX	700149FX	477322FX	475323FX	475322FX
3ØY 277/480	5	3+N+PE	7	477523FX	700147FX	477522FX	475523FX	475522FX
3ØY 347/600	5	3+N+PE	5	NA	700145FX	NA	NA	NA

Dimensional Drawings Page 464				IP 67	IP 44	IP 44
				<b>30A</b>	# of Wires	# of Poles
125	3	1+N+PE	4	477206FX	700224FX	477205FX
250	3	2+PE	6	477306FX	700226FX	477305FX
480	3	2+PE	7	477556FX	700227FX	477505FX
125/250	4	2+N+PE	12	477836FX	701232FX	477835FX
3Ø250	4	3+PE	9	477316FX	700239FX	477315FX
3Ø 480	4	3+PE	7	477516FX	700237FX	477515FX
3Ø 600	4	3+PE	5	NA	700235FX	NA
3ØY 120/208	5	3+N+PE	9	477326FX	700249FX	477325FX
3ØY 277/480	5	3+N+PE	7	477526FX	700247FX	477525FX
3ØY 347/600	5	3+N+PE	5	NA	700245FX	NA

Please Note that Dimensional Drawings are on the page indicated on the chart

Male Plugs mate with female connectors, panel mounted receptacles, & switched socket outlets. Male Plug Inlets mate with female connectors.

Dimensional Drawings Page 467 & 468				Male Plugs Page 467	Female Connectors & Receptacles Page 467			Male Inlet Page 468
				IP 67	IP 67	IP 67	IP 67	IP 67
<b>60A</b>	# of Wires	# of Poles	Ground-Clock Position	Part #	Part #	Part #	Part #	Part #
125	3	1+N+PE	4	477207FX	473207FX	536311FX	436311FX	476207FX
250	3	2+PE	6	477307FX	473307FX	536322FX	436322FX	476307FX
125/250	4	2+N+PE	12	477367FX	473837FX	546312FX	446312FX	476837FX
3Ø250	4	3+PE	9	477317FX	473317FX	546322FX	446322FX	476317FX
3Ø480	4	3+PE	7	477517FX	346350FX	546350FX	446350FX	476517FX
3Ø120/208	5	3+N+PE	9	477327FX	473327FX	556322FX	456322FX	476327FX
<b>100A</b>	# of Wires	# of Poles	Ground Position	Part #	Part #	Part #	Part #	Part #
125/250	4	2+N+PE	12	477368FX	473838FX	549312FX	449312FX	476838FX
3Ø250	4	3+PE	9	477318FX	473318FX	549322FX	449322FX	476318FX
3Ø480	4	3+PE	7	249550FX	349550FX	549550FX	449550FX	749550FX
3Ø120/208	5	3+N+PE	9	477328FX	473328FX	559322FX	459322FX	476328FX

# EPIC® Pin & Sleeve Connectors



## Selection Chart: North American Standards

Drawings Page 462 & 463			Female Connectors & Receptacles, Page 462					Male Inlets, Page 463	
			IP 67	IP 44	IP 67	IP 44	IP 44	IP 67	IP 44
<b>20A</b>	Ground-Clock	Position							
#	Poles		Part #	Part #	Part #	Part #	Part #	Part #	Part #
3	1+N+PE	4	473203FX	720124FX	471263FX	431611FX	471262FX	476203FX	476202FX
3	2+PE	6	473303FX	720126FX	471363FX	431622FX	471362FX	476303FX	476302FX
3	2+PE	7	473503FX	720127FX	471553FX	431650FX	471552FX	NA	NA
4	2+N+PE	12	473833FX	721132FX	471863FX	441612FX	471862FX	476833FX	476832FX
4	3+PE	9	473313FX	720139FX	471373FX	441622FX	471372FX	476313FX	476312FX
4	3+PE	7	473513FX	720137FX	471573FX	441650FX	471572FX	476513FX	476512FX
4	3+PE	5	NA	720135FX	NA	NA	NA	NA	NA
5	3+N+PE	9	473323FX	720149FX	471333FX	451622FX	471332FX	476323FX	476322FX
5	3+N+PE	7	473523FX	720147FX	471563FX	451650FX	471562FX	476523FX	476522FX
5	3+N+PE	5	NA	720145FX	NA	NA	NA	NA	NA

Drawings Page 464, 465, 466			Page 464	Page 464	Page 465	Page 465	Page 465	Page 466	Page 466
<b>30A</b>	Gnd-Clock	Position	Part #	Part #	Part #	Part #	Part #	Part #	Part #
#	Poles								
3	1+N+PE	4	473206FX	720224FX	471267FX	433211FX	471266FX	476206FX	476205FX
3	2+PE	6	473306FX	720226FX	471367FX	433222FX	471366FX	476306FX	476305FX
3	2+PE	7	473506FX	720227FX	471556FX	433250FX	471555FX	NA	NA
4	2+N+PE	12	473836FX	721232FX	471867FX	443212FX	471866FX	476836FX	476835FX
4	3+PE	9	473316FX	720239FX	471377FX	443222FX	471376FX	476316FX	476315FX
4	3+PE	7	473516FX	720237FX	471577FX	443250FX	471576FX	476516FX	476515FX
4	3+PE	5	NA	720235FX	NA	NA	NA	NA	NA
5	3+N+PE	9	473326FX	720249FX	471387FX	453222FX	471386FX	476326FX	476325FX
5	3+N+PE	7	473526FX	720247FX	471567FX	453250FX	471566FX	476526FX	476525FX
5	3+N+PE	5	NA	720245FX	NA	NA	NA	NA	NA





			Switched Socket Outlets					
			20A: Page 463		30A: Page 466		60A: Page 468	
			ULYSSE	ALUPRES	ULYSSE	ALUPRES	ULYSSE	ALUPRES
			IP 66/67	IP 65	IP 66/67	IP 65	IP 66/67	IP 55
#	Poles	Ground Position	Part #	Part #	Part #	Part #	Part #	Part #
3	1+N+PE	4	400124FX	460124FX	400224FX	460224FX	408324FX	460324FX
3	2+PE	6	400126FX	460126FX	400226FX	460226FX	408326FX	460326FX
3	2+PE	7	NA	NA	NA	NA	NA	NA
4	2+N+PE	12	401132FX	461132FX	401232FX	461232FX	418332FX	461332FX
4	3+PE	9	400139FX	460139FX	400239FX	460239FX	408339FX	460339FX
4	3+PE	7	400137FX	460137FX	400237FX	460237FX	408337FX	460337FX
4	3+PE	5	NA	NA	NA	NA	NA	NA
5	3+N+PE	9	400149FX	460149FX	400249FX	460249FX	408349FX	460349FX
5	3+N+PE	7	400147FX	460147FX	400247FX	460247FX	408347FX	460347FX
5	3+N+PE	5	NA	NA	NA	NA	NA	NA

### Voltage Key

3	125
3	250
3	480
4	125/250
4	3Ø250
4	3Ø 480
4	3Ø 600
5	3ØY 120/208
5	3ØY 277/480
5	3ØY 347/600

# EPIC® Pin & Sleeve Connectors







## Selection Chart: International Standards

Dimensional Drawings Page 461				Male Plugs				
								
16A	# of Wires	# of Poles	Ground-Clock Position	Part #	Part #	Part #	Part #	Part #
110 - 130	3	2+PE	4	477203	700124	477202	475203	475202
	4	3+PE	4	477213	700134	477212	475213	475212
	5	3+N+PE	4	477223	700144	477222	475223	475222
200 - 250	3	2+PE	6	477303	700126	477302	475303	475302
	4	3+PE	9	477313	700139	477312	475313	475312
	5	3+N+PE	9	477323	700149	477322	475323	475322
380 - 415	3	2+PE	9	477403	700129	477402	475403	475402
	4	3+PE	6	477413	700136	477412	475413	475412
	5	3+N+PE	6	477423	700146	477422	475423	475422
480 - 500	3	2+PE	7	477273	700127	477502	NA	NA
	4	3+PE	7	477513	700137	477512	475513	475512
	5	3+N+PE	7	477523	700147	477522	475523	475522
600 - 690	4	3+PE	5	NA	700135	NA	NA	NA
	5	3+N+PE	5	NA	700145	NA	NA	NA
440 - 460	4	3+PE	11	477453	700131	477452	475453	475452
	5	3+N+PE	11	477533	700141	477532	475533	475532

Please Note that Dimensional Drawings are on the page indicated on the chart

Dimensions are the same for North American and International Standards.

Male Plugs mate with Female connectors, panel mounted receptacles, & switched socket outlets. Male Plug Inlets mate with female connectors.

16A			Female Connectors Page 462		Female Receptacles Page 462			Male Inlets Page 463	
									
#	Poles	Ground	Part #	Part #	Part #	Part #	Part #	Part #	
3	2+PE	4	473203	720124	471263	431611	471262	476203	476202
4	3+PE	4	473213	720134	471273	441611	471272	476213	476212
5	3+N+PE	4	473223	720144	471223	451611	471222	476223	476222
3	2+PE	6	473303	720126	471363	431622	471362	476303	476302
4	3+PE	9	473313	720139	471373	441622	471372	476313	476312
5	3+N+PE	9	473323	720149	471333	451622	471332	476323	476322
3	2+PE	9	473403	720129	471463	431638	471462	476403	476402
4	3+PE	6	473413	720136	471473	441638	471472	476413	476412
5	3+N+PE	6	473423	720146	471483	451638	471482	476423	476422
3	2+PE	7	473503	720127	471553	431650	471552	NA	NA
4	3+PE	7	473513	720137	471573	441650	471572	476513	476512
5	3+N+PE	7	473523	720147	471563	451650	471562	476523	476522
4	3+PE	5	NA	720135	NA	NA	NA	NA	NA
5	3+N+PE	5	NA	720145	NA	NA	NA	NA	NA
4	3+PE	11	473463	720131	471583	441644	471582	476453	476452
5	3+N+PE	11	473533	720141	471593	451644	471592	476533	476532

# EPIC® Pin & Sleeve Connectors

## Selection Chart: International Standards

Dimensional Drawings Page 464				IP 67	IP 44	IP 44
<b>32A</b>	<b>Wires</b>	<b>Poles</b>	<b>Ground</b>	<b>Part #</b>	<b>Part #</b>	<b>Part #</b>
110 - 130	3	2+PE	4	477206	700224	477205
	4	3+PE	4	477216	700234	477215
	5	3+N+PE	4	477226	700244	477225
200 - 250	3	2+PE	6	477306	700226	477305
	4	3+PE	9	477316	700239	477315
	5	3+N+PE	9	477326	700249	477325
380 - 415	3	2+PE	9	477406	700229	477405
	4	3+PE	6	477416	700236	477415
	5	3+N+PE	6	477426	700246	477425
480 - 500	3	2+PE	7	477556	700227	477505
	4	3+PE	7	477516	700237	477515
	5	3+N+PE	7	477526	700247	477525
600 - 690	4	3+PE	5	NA	700235	NA
	5	3+N+PE	5	NA	700245	NA
440 - 460	4	3+PE	11	477456	700231	477455
	5	3+N+PE	11	477536	700241	477535

Please Note that Dimensional Drawings are on the page indicated on the chart





Dimensions are the same for North American and International Standards.

Male Plugs mate with Female connectors, panel mounted receptacles, & switched socket outlets. Male Plug Inlets mate with female connectors.

32A			Female Connectors Page 464		Female Receptacles Page 465			Male Inlets Page 466	
			IP 67	IP 44	IP 67	IP 44	IP 44	IP 67	IP 44
#	Poles	Ground	Part #	Part #	Part #	Part #	Part #	Part #	Part #
3	2+PE	4	473206	720224	471267	433211	471266	476206	476205
4	3+PE	4	473216	720234	471277	443211	471276	476216	476215
5	3+N+PE	4	473226	720244	471287	453211	471286	476226	476225
3	2+PE	6	473306	720226	471367	433222	471366	476306	476305
4	3+PE	9	473316	720239	471377	443222	471376	476316	476315
5	3+N+PE	9	473326	720249	471387	453222	471386	476326	476325
3	2+PE	9	473406	720229	471467	433238	471466	476406	476405
4	3+PE	6	473416	720236	471477	443238	471476	476416	476415
5	3+N+PE	6	473426	720246	471487	453238	471486	476426	476425
3	2+PE	7	473506	720227	471556	433250	471555	NA	NA
4	3+PE	7	473516	720237	471577	443250	471576	476516	476515
5	3+N+PE	7	473526	720247	471567	453250	471566	476526	476525
4	3+PE	5	NA	720235	NA	NA	NA	NA	NA
5	3+N+PE	5	NA	720245	NA	NA	NA	NA	NA
4	3+PE	11	473466	720231	471587	443244	471586	476456	476455
5	3+N+PE	11	473536	720241	471597	453244	471596	476536	476535







# EPIC® Pin & Sleeve Connectors





## Selection Chart: International Standards

				Page 463		Page 466	
				ULYSEE IP 66/67 	16A ALUPRES IP 65 	ULYSEE IP 66/67 	32A ALUPRES IP 65 
				with Fuse Holder	Direct Connect	with Fuse Holder	Direct Connect
				Part #	Part #	Part #	Part #
110 - 130	# of Wires	Poles	Ground-Clock Position				
	3	2+PE	4	400124	460124	400224	460224
	4	3+PE	4	400134	NA	400234	NA
200 - 250	5	3+N+PE	4	400144	NA	400244	NA
	3	2+PE	6	400126	460126	400226	460226
	4	3+PE	9	400139	460139	400239	460239
380 - 415	5	3+N+PE	9	400149	NA	400249	460249
	3	2+PE	9	400129	NA	400229	460229
	4	3+PE	6	400136	460136	400236	460236
480 - 500	5	3+N+PE	6	400146	460146	400246	460246
	4	3+PE	7	400137	NA	400237	460237
	5	3+N+PE	7	400147	NA	400247	460247
440 - 460	4	3+PE	11	400131	NA	400231	460231
	5	3+N+PE	11	400141	NA	400241	460241

Please Note that Dimensional Drawings are on the page indicated on the chart

Dimensions are the same for North American and International Standards.

			Page 463		Page 467		Page 468	
			IP 67 	IP 67 	IP 67 	IP 67 	IP 67 	IP 66/67 w/fuse holder 
#	Poles	Clock Position	Part #	Part #	Part #	Part #	Part #	Part #
3	2+PE	4	477207	473207	536311	436311	476207	400324
4	3+PE	4	477217	473217	546311	446311	476217	400334
5	3+N+PE	4	477227	473227	556311	456311	476227	400344
3	2+PE	6	477307	473307	536322	436322	476307	400326
4	3+PE	9	477317	473317	546322	446322	476317	400339
5	3+N+PE	9	477327	473327	556322	456322	476327	400349
3	2+PE	9	477407	473407	536338	436338	476407	400329
4	3+PE	6	477417	346338	546338	446338	746338	400336
5	3+N+PE	6	477427	356338	556338	456338	756338	400346
4	3+PE	7	477517	346350	546350	446350	476517	400337
4	3+PE	11	477457	473467	546344	446344	476457	400331
5	3+N+PE	11	477537	473537	556344	456344	476537	400341

			Page 469				Page 470
			IP 67 	IP 67 	IP 67 	IP 67 	IP 67 
#	Poles	Clock Position	Part #	Part #	Part #	Part #	
4	3+PE	4	477218	473218	549311	449311	476218
5	3+N+PE	4	477228	473228	559311	459311	476228
4	3+PE	9	477318	473318	549322	449322	476318
5	3+N+PE	9	477328	473328	559322	459322	476328
4	3+PE	6	249538	349538	549538	449538	749538
5	3+N+PE	6	259538	359538	559538	459538	759538
4	3+PE	7	249550	349550	549550	449550	749550
4	3+PE	11	477458	473468	549344	449344	476458
5	3+N+PE	11	477538	473538	559344	459344	476538

Male plugs mate with female connectors, panel mounted receptacles, & switched socket outlets. Male plug inlets mate with female connectors.

# EPIC® Pin & Sleeve Connectors

North American 20A & International 16A Dimensional Data

## Male Plugs

### TECHNICAL DATA:

**Impact Resistance:** 8J

**Ambient Temperature:** -25°C to +70°C

**Flame Resistance:**

Glow Wire Test: Enclosure: 850°C

Glow Wire Test: Contact Carrier: 850°C

Self-Extinguishing: Enclosure: UL94- V2

Self-Extinguishing: Contact Carrier: UL94-V2

### CEE Series Straight with Cable Gland (IP67)

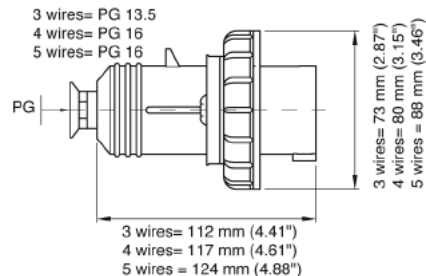

### CEE Series 90° with Cable Gland (IP 67)

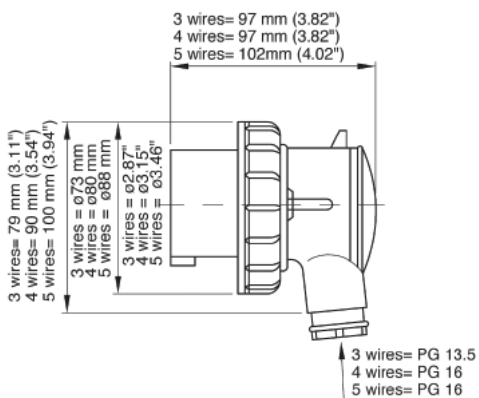

### MULTIMAX with cable sleeve (IP 44)

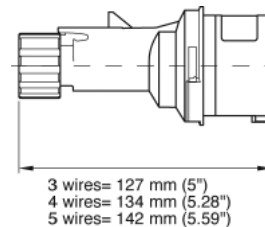

### CEE Series Straight with cable gland (IP 44)

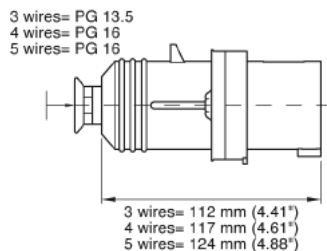

### CEE Series 90° with Cable Gland (IP 44)

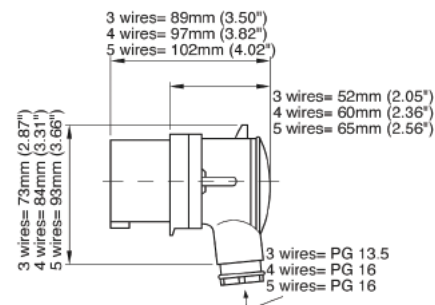

# EPIC® Pin & Sleeve Connectors

North American 20A & International 16A Dimensional Data

## Female Connectors

### CEE Series Straight with Cable Gland (IP 67)

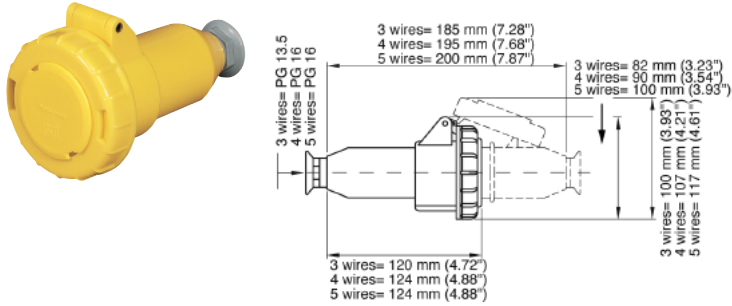

### MULTIMAX with cable sleeve (IP 44)

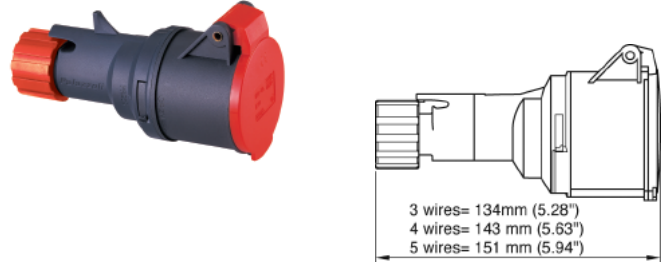

## Female Receptacles

### CEE Series Angled Panel Mount (IP 67)

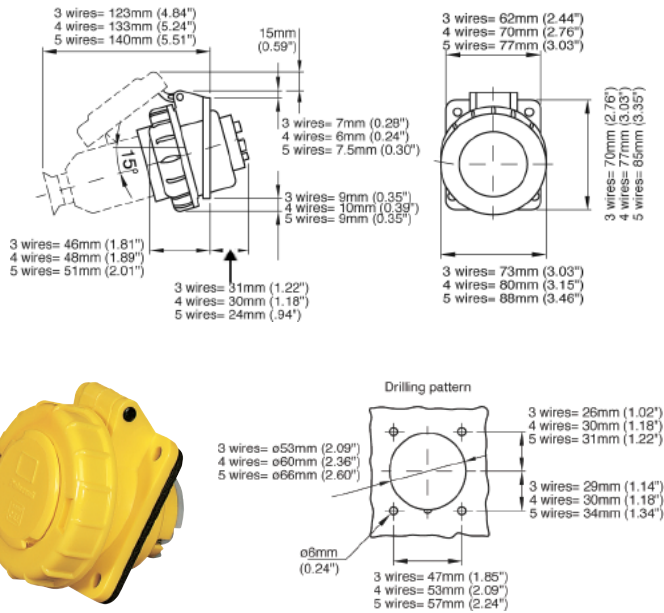

### CEE Series Straight Panel Mount (IP 44)

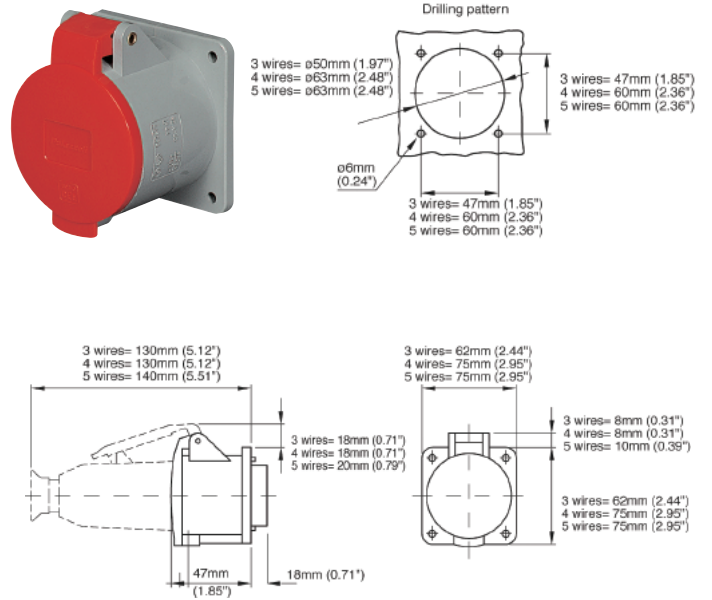

### CEE Series 75° Internal Surface Mount (IP 44)

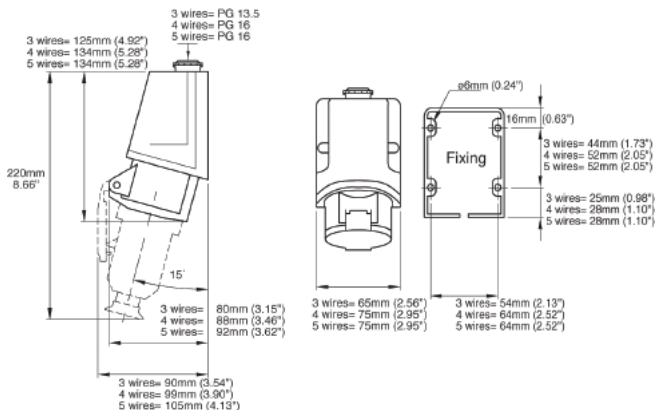

# EPIC® Pin & Sleeve Connectors

North American 20A & International 16A Dimensional Data

## Male Plug Inlets

CEE Series Angled 82° Inlet (IP 67)

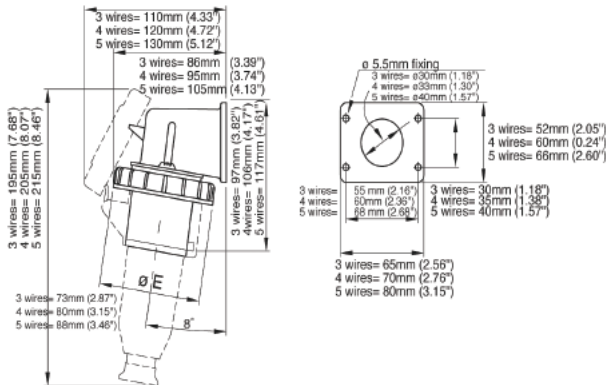
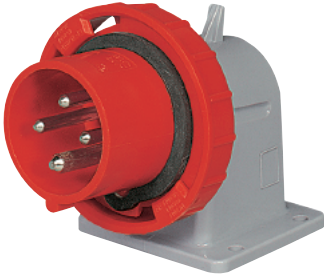

CEE Series Angled 82° Inlet (IP 44)

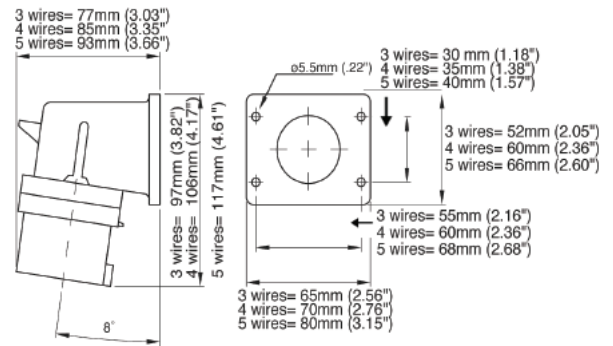
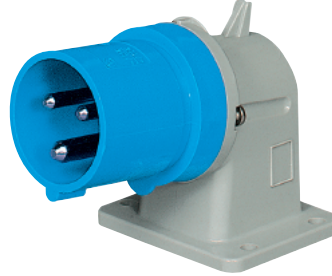

## Switched Socket Outlets with Mechanical Interlock

ULYSSE Series: Thermoset Plastic Enclosures with Fuse Holder (IP66 & IP 67)

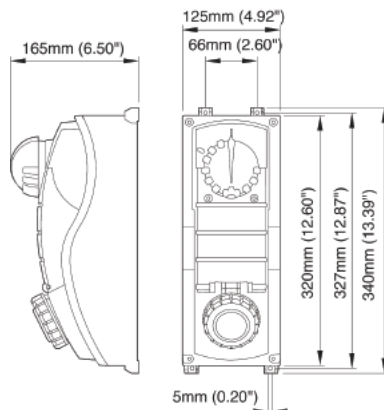

ALUPRES Series: Aluminum Enclosures Direct Connect (IP 65)

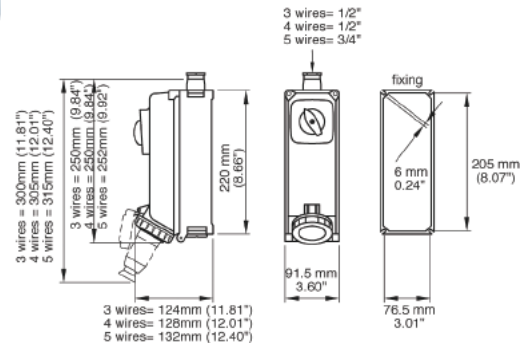

# EPIC® Pin & Sleeve Connectors

North American 30A & International 32A Dimensional Data

## Male Plugs

### TECHNICAL DATA:

**Impact Resistance:** 8J

**Ambient Temperature:** -25°C to +70°C

**Flame Resistance:**

Glow Wire Test: Enclosure: 850°C

Glow Wire Test: Contact Carrier: 850°C

Self-Extinguishing: Enclosure: UL 94-V2

Self-Extinguishing: Contact Carrier: UL 94-V2

### CEE Series Straight with Cable Gland (IP 67)

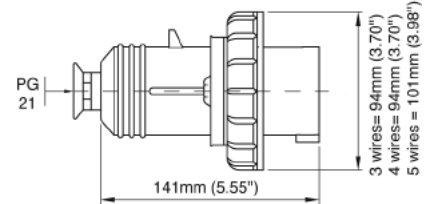

### MULTIMAX with cable sleeve (IP 44)

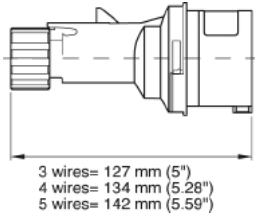

### CEE Series Straight with cable gland (IP 44)

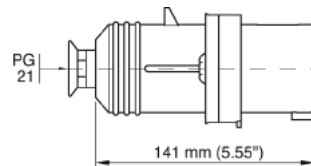

## Female Connectors

### CEE Series Straight with Cable Gland (IP 67)

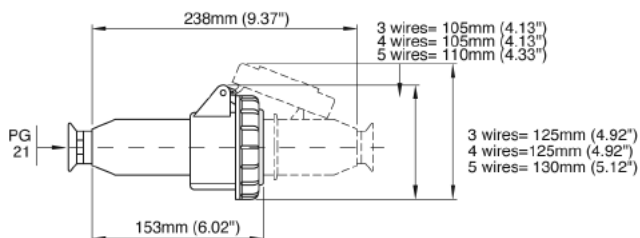

### MULTIMAX with cable sleeve (IP 44)

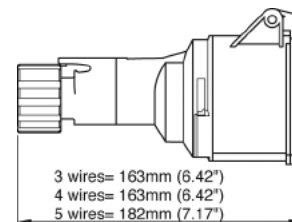

# EPIC® Pin & Sleeve Connectors

North American 30A & International 32A Dimensional Data

## Female Receptacles

### CEE Series Angled Panel Mount (IP 67)

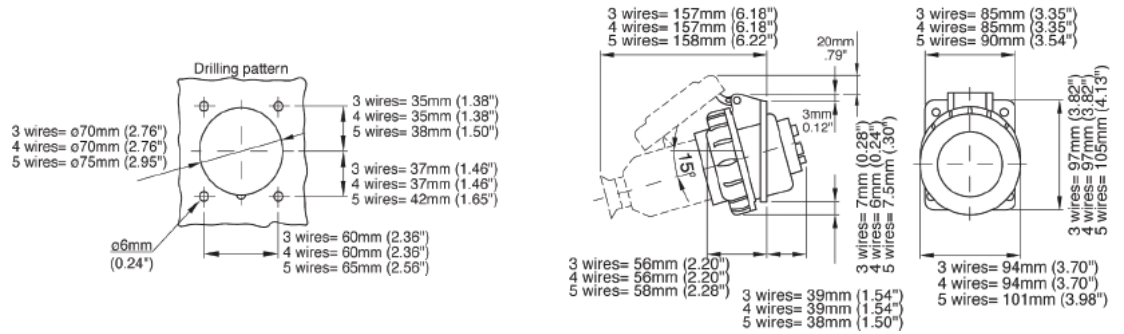

### CEE Series Straight Panel Mount (IP 44)

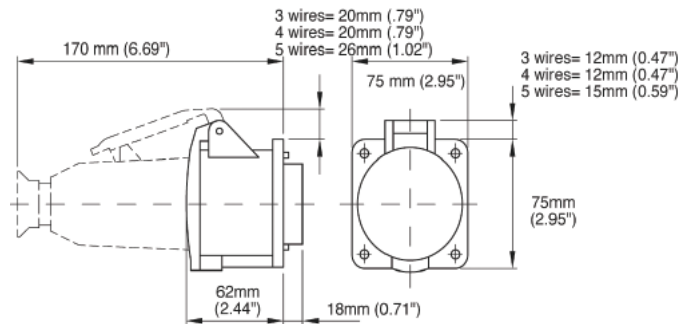
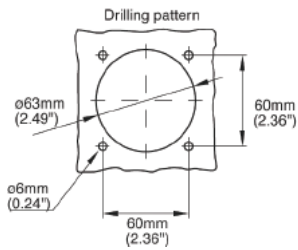

### CEE Series 75° Internal Surface Mount (IP 44)

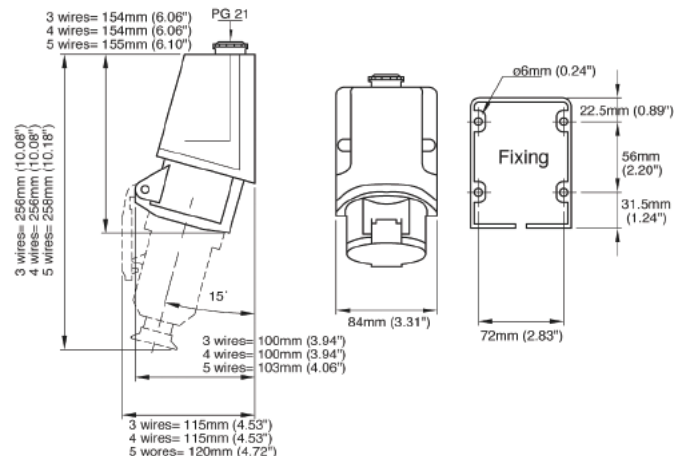
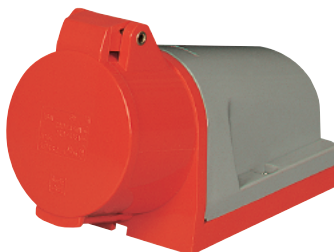



# EPIC® Pin & Sleeve Connectors

North American 60A & International 63A Dimensional Data

## Male Plugs

### TECHNICAL DATA:

**Impact Resistance:** 8J  
**Ambient Temperature:** -25°C to +70°C  
**Flame Resistance:**  
 Glow Wire Test: Enclosure: 850°C  
 Glow Wire Test: Contact Carrier: 960°C  
 Self-Extinguishing: Enclosure: UL 94-V2  
 Self-Extinguishing: Contact Carrier: UL 94-V0

### CEE Series Straight with Cable Gland (IP 67)

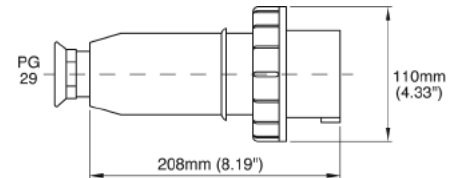

## Female Connectors

### CEE Series Straight with Cable Gland (IP 67)

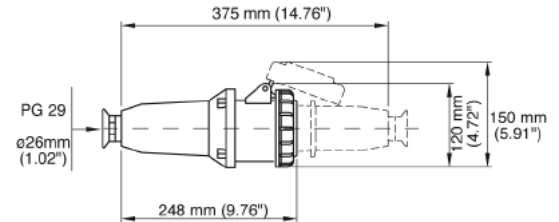
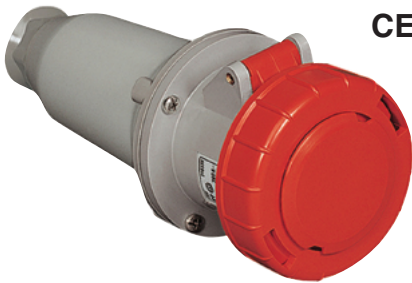

## Female Receptacles

### CEE Series Angled Panel Mount (IP 67)

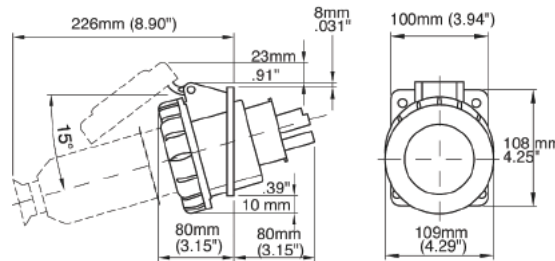
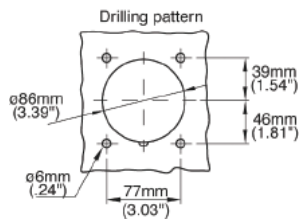

### CEE Series Straight Panel Mount (IP 67)

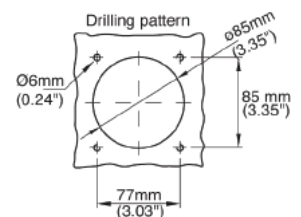
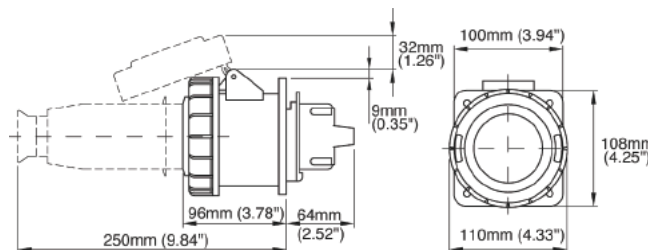

# EPIC® Pin & Sleeve Connectors

North American 60A & International 63A Dimensional Data

## Male Plug Inlets

CEE Series Straight Panel Mount Inlet (IP 67)

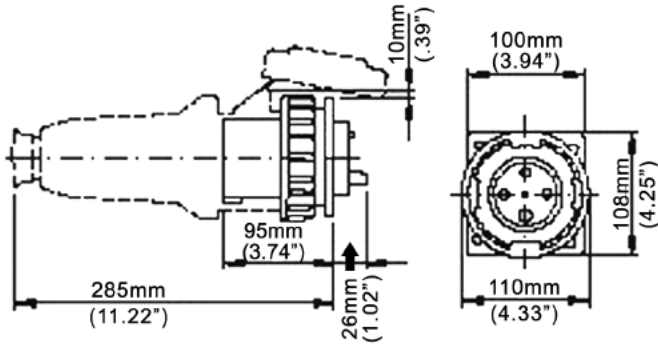

## Switched Socket Outlets with Mechanical Interlock

ULYSEE Series: Thermoset Plastic Enclosures (IP 66 & IP 67)

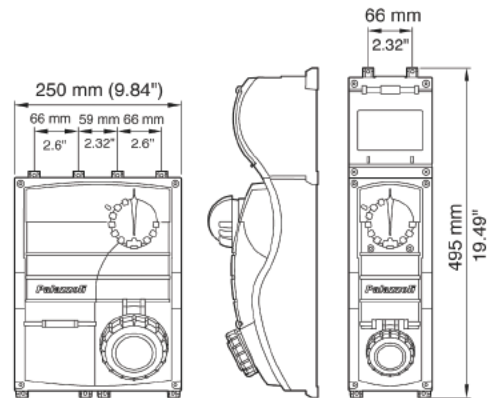

ALUPRES Series: Aluminum Enclosures (IP 55)

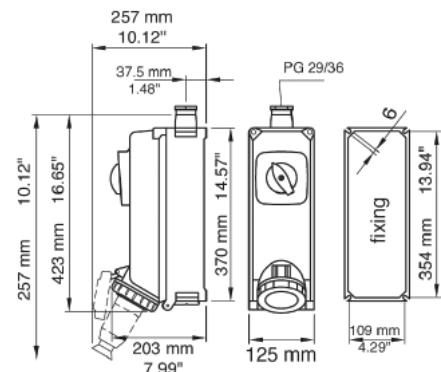

# EPIC® Pin & Sleeve Connectors

North American 100A & International 125A Dimensional Data

## Male Plugs

CEE Series Straight with Cable Gland (IP 67)

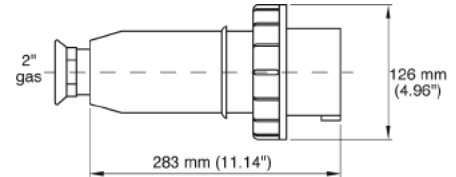

## Female Connectors

CEE Series Straight with Cable Gland (IP 67)

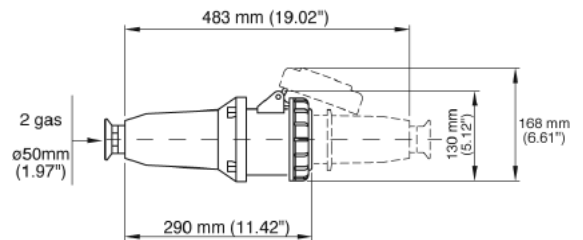

## Female Receptacles

CEE Series Angled Panel Mount (IP 67)

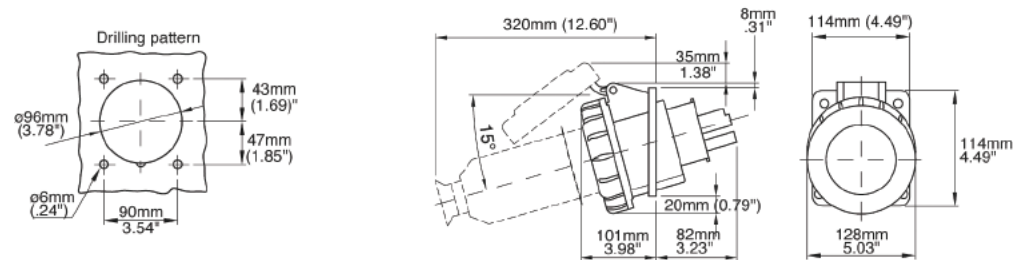

CEE Series Straight Panel Mount (IP 67)

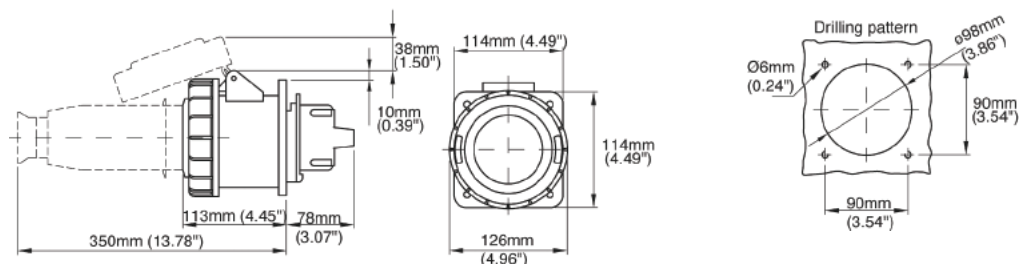
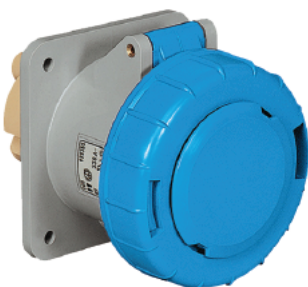

# EPIC® Pin & Sleeve Connectors

North American 100A & International 125A Dimensional Data

## Male Plug Inlets

CEE Series Straight Panel Mount Inlet (IP 67)

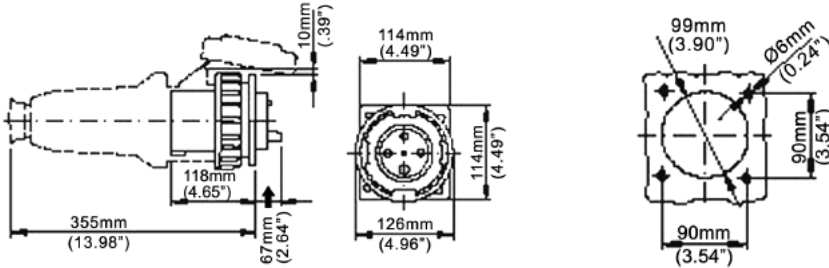

## Watertight Covers for Male Plugs and Inlets (IP 67)

Amps	Plug Types	Part Number
20/16	2+PE	476903
	3+PE	476913
	3+N+PE	476923
30/32	2+PE	476905
	3+PE	476905
	3+N+PE	476925
60/63	ALL	PC60
100/125	ALL	PC100



## Flanges with Cable Glands for ALUPRES Switched Socket Outlets

Flat Flange

Raised Flanges



	Window	For Cable Diameter (mm)	Thread Type	Part Number
20/16 Amps	F0 (Flat)	12 - 16	1/2"	541080FX *
		16 - 20	3/4"	541090FX **
		20 - 25-5	1"	541030FX
		2 x 12-16	1/2"	541040
30/32 Amps	F1 (Raised)	22 - 25.5	1"	540151FX
		26 - 36	1 1/4"	540141FX
		2 x 16-20	3/4"	540161

\* Supplied with 20/16 Amp ALUPRES: 2+PE, 3+PE

\*\* Supplied with 20/16 Amp ALUPRES: 3+N+PE

## Fuses for ULYSSE Switched Socket Outlets

ULYSSE Switch Socket Outlets use standard IEC60269 cylindrical fuses. Fuse selection is application specific and typically based on providing shortcircuit line protection (gL-gG fast-acting type) or motor protection (aM slow acting type). Consult with a fuse manufacturer (eg. Littlefuse, Bussmann, etc.) for proper selection and to place an order. (Lapp does not carry fuses.) The table below shows general fuse information for each ULYSSE Outlet size. Order one fuse or each outlet pole (ex. 400139FX 250V, 20A, 3+PE outlet requires (3) 10 x38 fuses).

Switch Outlet Rating (Amps)	Fuse Size AxB (mm)	Fuse Current Rating (Amps)	Fuse Voltage Rating (Volts)
20/16	10x38	0.5 - 32	500V
30/32	14x51	2 - 50	500V
63	22x58	16 - 100	500V

# EPIC® Pin & Sleeve Connectors

## Harmonized/ UL Cordsets

These pre-assembled and tested cable connector/cord sets are easy to order and stock. They speed initial installation and replacement, minimizing installation cost and downtime. They are available in several popular international and North American voltage and current configurations, and are typically ready for shipment within

a few days. In addition, these assemblies are available in other cable lengths and other configurations using any of our wide offering of EPIC® Pin & Sleeve connectors and cables. Please contact a representative with your specific requirements for a custom cord set.

**Type A:  
Plug  
& Pigtail**

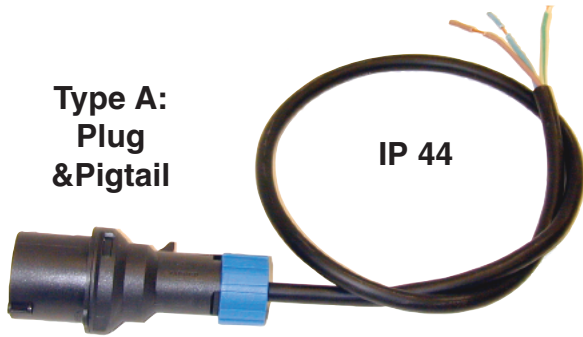

IP 44

**Type B:  
Connector  
& Pigtail**

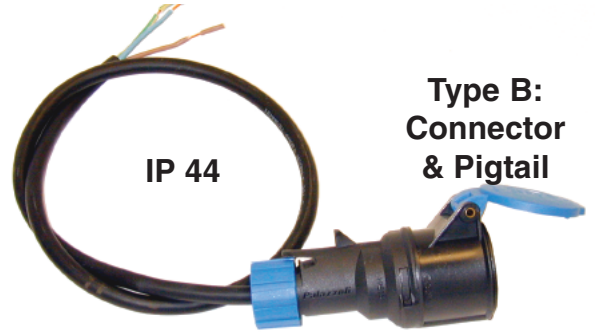

IP 44

**Type C:  
Plug & Connector**

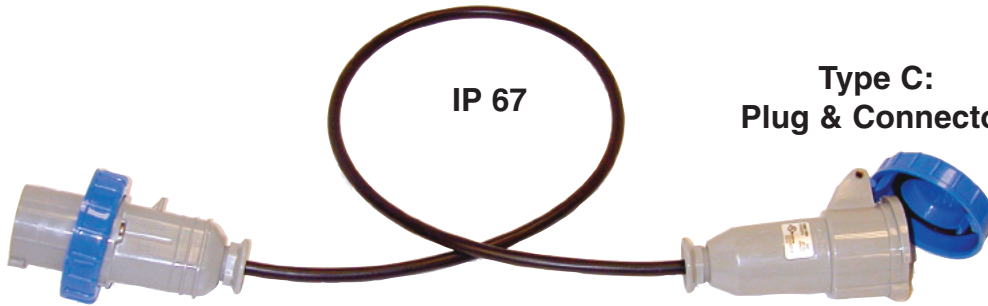

IP 67

**Type A:  
Plug &  
Pigtail**

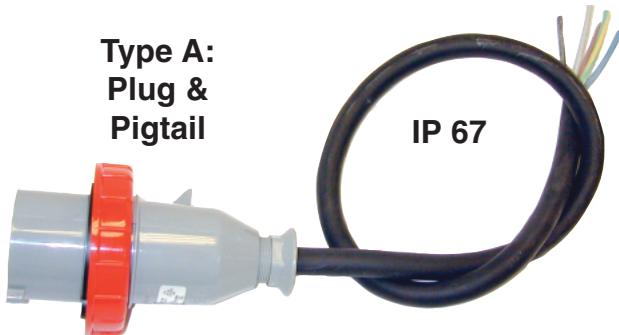

IP 67

**Type B:  
Connector  
& Pigtail**



IP 67

**Type C:  
Plug & Connector**

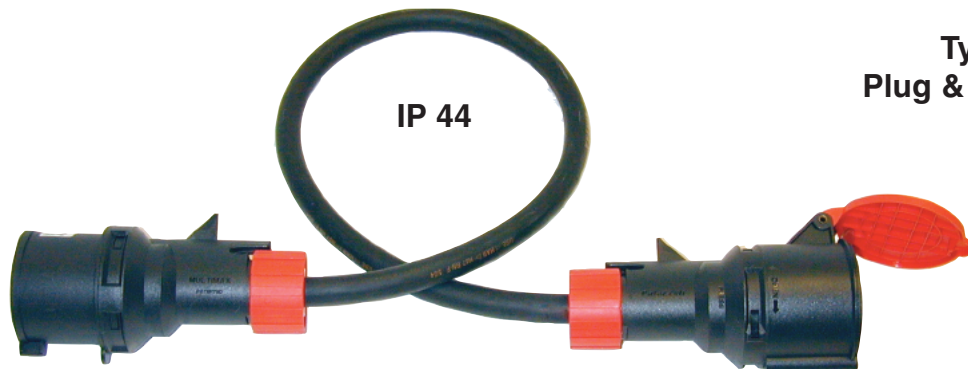

IP 44

# EPIC® Pin & Sleeve Connectors

IEC & UL Standards

Founded in 1906, the International Electrotechnical Commission (IEC) is the global organization that prepares and publishes international standards for all electrical, electronic and related technologies. The IEC was founded as a result of a resolution passed at the International Electrical Congress held in St. Louis (USA) in 1904. The membership consists of more than 60 participating countries, including all the world's major trading nations and a growing number of industrialized countries.

The IEC's mission is to promote international cooperation on all electrotechnical standardization questions and related matters in the fields of electricity, electronics, and related technologies. IEC's international standards insure that a component or system manufactured to IEC standards and manufactured in country A can be sold and used in countries B through Z.

## **IEC 60309-1 (1999-02) Plugs, socket-outlets and couplers for industrial purposes- Part 1: General Requirements**

Applies to plugs and socket-outlets, cable couplers and appliance couplers, with a rated operating voltage not exceeding 690V D.C. or A.C., 500 Hz A.C. and a rated current not exceeding 250 A, primarily intended for industrial use, either indoors or outdoors when the ambient temperature does not normally exceed 40°C.

## **IEC 60309-2 (1999-04) Plugs, socket-outlets and couplers for industrial purposes- Part 2: Dimensional interchangeability requirements for pin and contact-tube accessories.**

Applies to plugs and socket-outlets, cable couplers with a rated operating voltage not exceeding 690V, 500Hz and a rated current not exceeding 125A., primarily intended for industrial use, either indoors or outdoors. Together, the IEC 60309 standards provide industrial pin and sleeve connectors that are coded to provide positive voltage and frequency matching. Physical characteristics of these connectors make it virtually impossible to mis-match plugs and receptacles of different voltage and current ratings. The size of the device is determined by its amperage rating. Devices with different amperage ratings cannot be coupled due to the size variance used.

Pin & Sleeve devices conforming to IEC309-2 are single rated with their voltage determined by the location of the oversized female ground contact relative to a key way molded into the bottom of the housing. Twelve positions are possible (conforming to the positions on a clock face)

to represent the ground pin location for specific voltages. Mismatched voltage devices are impossible to couple. In addition, each device is clearly marked and color coded to indicate the voltage for which it is intended to be used.

As a result of this standardization, all manufacturers' devices which conform to these standards are intermateable and interchangeable.

All North American products in this catalog are designed, tested, and approved by Underwriters Labs in accordance with UL 1682 and UL 1686 standards.

## **UL 1682 Plugs, Receptacles and Cable Connectors of the Pin & Sleeve Type**

Describes the electrical and mechanical characteristics

## **UL 1686 Pin & Sleeve Configurations**

Describes contact location and other requirements relative to voltage rating for interchangeability.

The following charts show the ground pin location (referenced to the female connector) and color coding for both the North American and International product configurations.

# EPIC® Pin & Sleeve Connectors

North American & International Standards: Ground Pin Location & Voltage

## NORTH AMERICAN

**3 Wires: 2+PE & 1+N+PE**

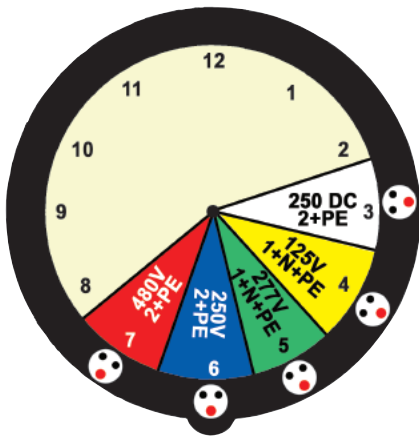

Ground Pin location is specified for the female connector referenced to the hour positions on the face of a clock.

**4 Wires: 2+N+PE & 3+PE**

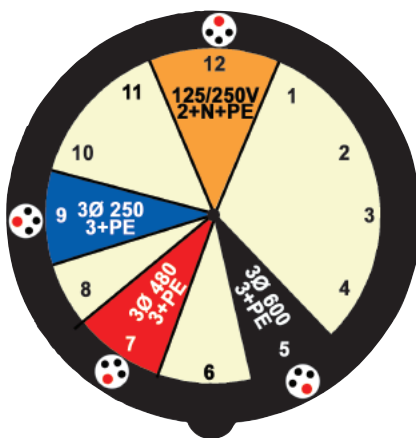

**5 Wires: 3+N+PE**

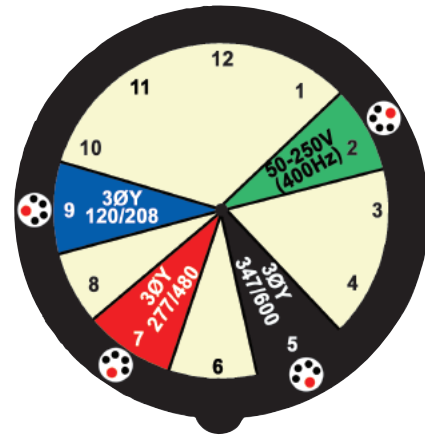

Key way is always at the 6 o'clock position

## INTERNATIONAL

**3 Wires: 2+PE**



Color Slices represent Voltages

**4 Wires: 3+PE**

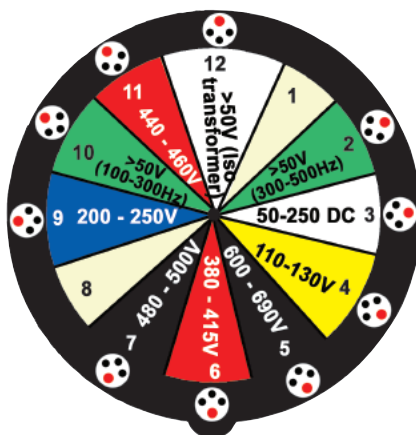

**5 Wires: 3+N+PE**

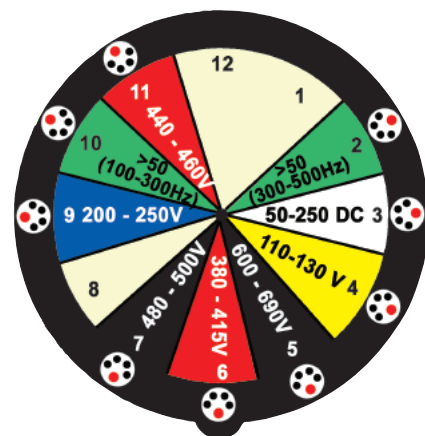

Voltage is represented by color of the connector.

# EPIC® Pin & Sleeve Connectors

## Technical Data: Key Features

### KEY FEATURES:

#### MULTIMAX:

- Patented click-lock housing
- Patented integral cable grip with shade ring locking device
- Patented universal membrane seal
- High copper, solid brass contacts

#### CEE Series:

- Integral cable clamp
- Peelable neoprene grommet
- PG threaded cable gland
- Stainless steel assembly screws
- High copper, solid brass contacts with nickel plated male pins

#### Common Features:

- Tough Type 6 Nylon Housing
- Make first/break last ground contact
- Voltage polarized contacts and color coded housings
- Conformance to IEC 60309-1, -2; UL 1682 and 1686 approved.

#### **ELECTRICAL:**

Dielectric Voltage Withstand	Up to 3000 volts for 1 minute
Maximum Working Voltage	600 volts (North American); 690 volts (International)
Insulation Resistance	5 megohms minimum
Overload	150% rated current at rated voltage for 50 make/break cycles
Current Interrupting / Load Breaking	Tested to 125% rated current at 110% rated voltage per IEC 60309-1
Conditional Short Circuit Current	clause 20
Endurance, Connect and Disconnect Cycles	10k amps at rated voltage per IEC 60309-1 clause 29
Ground Path Current	See Table 2
	See Table 1

#### **MECHANICAL:**

Impact Resistance (-25°C for 6 hours)	Per UL 1682 Section 34 and IEC 60309-1 Clause 24
Crush Resistance (-25°C for 6 hours)	250 pounds for 1 minute
Withdrawal Force	See Table 4
Cable Secureness	See Table 3
Polarization Integrity	Maintained by oversized ground pin and "clock key"
Wire Size Accommodation	See Table 6
Cable OD Accommodation	See Table 5

#### **ENVIRONMENTAL:**

Operating Temperature Range	Plugs, Connectors, Outlets, Inlets: -25° to +70° C Interlocked Switch Outlets: -40° to +70°C
Flammability (self-extinguishing)	<ul style="list-style-type: none"> <li>• Contact Holders 20A &amp; 30A (16A &amp; 32A): Glow Wire 850°C (UL94-V2)</li> <li>• Contact Holders 60A &amp; 100A (63A &amp; 125A): Glow Wire 960°C (UL94-V0)</li> <li>• Other components: Glow Wire 650°C</li> <li>• ULYSSE Interlocked Switch Outlet Housing: Glow Wire 960°C (UL94-V0)</li> </ul>
Moisture Resistance	<ul style="list-style-type: none"> <li>• MULTIMAX: IP44 (Indoor Splash Proof)</li> <li>• CEE Series: IP44 (Indoor Splash Proof); IP67 (Indoor/Outdoor Watertight)</li> <li>• ULYSSE: IP66 &amp; IP67 (Indoor/Outdoor Watertight)</li> <li>• ALUPRES: IP55 &amp; IP65 (Indoor/Outdoor Watertight)</li> </ul>
Corrosion Resistance	External screws and cover springs are stainless steel. Contact pins for CEE Series are nickel plated brass
Chemical Resistance	Resists standard industrial hydrocarbons, acids, bases, and solvents
UV Resistance	Exposed plastic materials are UV stabilized

ALL ABOVE DATA, WHERE APPLICABLE, ARE ACCORDING TO "IEC 60309" STANDARD.

# EPIC® Pin & Sleeve Connectors

Technical Data: Test Data & Cable OD Accommodation

**TABLE 1**  
**GROUND PATH CURRENT TEST**

Device Rating Amperes	Minimum Size Grounding AWG	Conductor mm <sup>2</sup>	Time in Seconds	Test Current Amperes
20	12	3.3	4	470
30	10	5.3	4	750
60	10	5.3	4	750
100	8	8.4	4	1180

A test current that far exceeds the device rating is passed through the mating device and grounding wires.

**TABLE 2**  
**ENDURANCE TEST**

Device Rating Amperes	Cycles with load at rated current and voltage	No-Load Cycles	Sequence
20	5000	0	-
30	1000	1000	Alternating
60	1000	1000	Alternating
100	250	250	Alternating

The test sequence is conducted using a no-load, followed by a load sequence. The power factor of the load is 0.75 to 0.80.

**TABLE 3**  
**CABLE SECURENESS TEST**

Device Rating Amperes	Force		Torque		Maximum Displacement	
	lb.	N	ft-lb	N•M	Inches	mm
20	30	133	0.4	0.54	3/32	2.38
30	75	333	0.5	0.68	3/32	2.38
60	150	667	1.0	1.4	3/32	2.38
100	150	667	2.0	2.7	3/32	2.38

The flexible cord or cable is simultaneously twisted and pulled. Values for the applied twisting torque and force of pull are shown in table 3. In all cases the cord displacement is less than 3/32.

**TABLE 4**  
**WITHDRAWAL FORCE TEST**

Device Rating Amperes	Minimum Withdrawal Force	
	lb.	N
20	5	22
30	6	27
60	15	67
100	20	89

The pressure exerted by mating contacts of a plug and a connector must be sufficient to prevent unintentional withdrawal during normal use. During the test any locking rings or retaining means are not to be engaged.

**TABLE 5**  
**CABLE OD ACCOMMODATION**

Product	Sleeve/Cable Gland (PG)	Cable Diameter min-max 2+PE (mm)	Cable Diameter min-max 3+PE (mm)	Cable Diameter min-max 3+N+PE (mm)
MULTIMAX: 20/16A	-	8.1 - 14	8.5 - 14	10 - 15.3
MULTIMAX: 30/32A	-	11.5 - 17.3	12.5 - 19.3	14 - 21.3
CEE: 2P+PE, 20/16A	13.5	8.1 - 13.5	-	-
CEE: 3P+PE, 20/16A	16	-	8.8 - 15.3	-
CEE: 3P+N+PE, 20/16A	16	-	-	8.8 - 15.3
CEE: 30/32A	21	11.5 - 21.3	11.5 - 21.3	11.5 - 21.3
CEE: 60/63A	29	16 - 28.5	16 - 28.5	16 - 28.5
CEE: 100/125A	2" Gas	26 - 49	26 - 49	26 - 49.0
ULYSSE: 20/16A	29	17.3 - 26	19.3 - 28.5	21.3 - 31.3
ULYSSE: 30/32A	29	17.3 - 26	19.3 - 28.5	21.3 - 31.3
ULYSSE: 60/63A	2 x 29	17.3 - 26	19.3 - 28.5	21.3 - 31.3
ALUPRES: 20/16A, 2P+PE & 3P+PE	1/2" Gas (NPT) 3/4" Gas (NPT)	11.5 - 17.3 -	12.5 - 19.3 -	- 14 - 21.3
ALUPRES: 20/16A, 3P+N+PE	1/2" Gas (NPT)	Min 12 - Max 16		
ALUPRES: 30/32A & 60/63A	3/4" Gas (NPT)	Min 16 - Max 20		
(choose and order separately)	1" Gas (NPT)	Min 22 - Max 25.5		
	1 1/4" Gas (NPT)	Min 26 - Max 36		

# EPIC® Pin & Sleeve Connectors

Technical Data: Wire Size Accommodation & Construction Materials

**TABLE 6**  
**WIRE SIZE ACCOMMODATION**

Connector Rated Current NA/Intl	Largest Wire Size* Accommodated AWG (mm <sup>2</sup> )	Recommended Contact Set Screw Torque CEE foot pounds (Nm)	Recommended Contact Set Screw Torque MULTIMAX foot pounds (Nm)
20/16A	12 (4)	0.6 (0.8)	0.6 (0.8)
30/32A	8 (10)	2 x 0.6 (0.8)	1.48 (2)
60/63A	6 (16)	2 x 1.48 (2)	-
100/125A	1 (50)	2 x 2.95 (4)	-

\* subject to stranding configuration

## CONSTRUCTION MATERIALS

PLUG, CONNECTOR, RECEPTACLE, INLET	
Housing	Thermoplastic
Cable Grip	Thermoplastic
Cover (Splashproof)	Thermoplastic
Locking Ring/Cover (Watertight)	Thermoplastic
Contact Carrier (20/16A; 30/32A)	Thermoplastic
Contact Carrier (60/63A; 100/125A)	Thermoset Plastic
Cable Grommet/Seal	Neoprene
Locking Ring Gasket	Neoprene
Flange Seal Gasket	Neoprene
Contact Pins (MULTIMAX)	High-copper Brass
Contact Pins (CEE)	High-Plated, High-copper Brass
Contact Sleeves	High-Copper Brass
Terminal Screws (Splashproof)	Brass
Terminal Screws (Watertight)	Nickel-Plated Brass
Assembly Screws	Stainless Steel
Cover Spring	Stainless Steel

## CONSTRUCTION MATERIALS

INTERLOCKED SWITCHED SOCKETS	ULYSSE	ALUPRES
Housing	Thermoset Plastic	Aluminum Alloy with baked polymerized paint finish
Control Grip	Thermoset Plastic	Thermoplastic
Locking Ring/ Cover	Thermoplastic	Thermoplastic
Entry Gland	Thermoplastic	-
Contact Carrier (20/16A; 30/32A)	Thermoplastic	Thermoplastic
Contact Carrier (60/63A)	Thermoset Plastic	Thermoset Plastic
Cable Grommet	Neoprene	Neoprene
Locking Ring Gasket	Neoprene	Neoprene
Contact Sleeves	High-copper Brass	High-copper Brass
Terminal Screws	Brass	Brass
Mechanical Interlock	Tropicalized Steel	Tropicalized Steel
Switch Lock-out Device	Stainless Steel	-
Assembly Screws	Stainless Steel	Stainless Steel
Cover Spring	Stainless Steel	Stainless Steel

# EPIC® Pin & Sleeve Connectors

## Technical Data: Plugs & Connectors Reference Data

### Reference Standards:

- General Characteristics: • CEI EN 60309-1 • IEC 309 • CEI 23-12/1
- Standardization: • CEI EN 60309-2 • IEC 309-2 • CEI 23-12/2
- Protection Ratings: • CEI EN 60529 • IEC 529 • CEI 70-1

### Constructional characteristics of both the IP 44 and the IP 67 versions:

- Pins and plug contacts are made of solid brass bars with a high level of copper.
- External screws, where present, and spring clasps for lids are made of stainless steel.
- The cable clamp is designed to prevent strain from torque and/ or traction on the wires in the terminals, also assures that the wire covering stays in good condition.
- Elements holding live parts are made (for 20A and 30A North American or 16A and 32 A International power) in self-extinguishing thermoplastic technopolymer (UL94-V2), with GLOW-WIRE resistance to 850°C and resistance to tracking of >600V. For 60A and 100A North American and 63A and 125A International, they are made of self extinguishing thermoset technopolymer (UL94-V0), with GLOW- WIRE resistance to 960°C and resistance to tracking of >600V.
- Body and lids are made of technopolymer with high impact resistance and excellent dimensional stability.

### Constructional characteristics of the IP 67 versions:

- Pins are subject to a thick nickel-plating treatment to increase their resistance to oxidation and wear even under the worst operating conditions.
- 60A and 100A North American and 63A and 125A international types are inclusive of a standard pilot contact.
- Cable glands have parts in peelable rubber for adapting them to the size of the cable used.
- 60A and 100A North American and 63A and 125A International plug and socket-outlet bodies are made of extra-durable thermoplastic technopolymer to assure improved impact resistance even under extreme conditions.

### Resistance to excess heat and fire:

Glow-wire test (according to Publication IEC 695-2-1): This test checks the reaction of a given insulation after overheating of adjacent metallic parts caused by bad connections or faults in the system.

A glow wire coil is pressed into the specimen for 30 seconds, penetrating up to 7mm. A sheet of tissue paper is put under the point of contact. The temperature of the wire required by the standards is 850°C for items used for

holding parts that carry current, and 650°C for other insulations. The test is considered to have a positive outcome if the specimen does not catch fire, or if it self extinguishes within 30 seconds of the wire being removed without burning entirely and causing continuous burning of the tissue paper beneath.

All plugs and connector components meet or exceed the temperature test requirements set by IEC.

### UL 94: Self extinguishing test:

A bunsen burner is twice brought into contact with an insulation specimen in a vertical position, each time lasting 10 seconds. Cotton wool is placed under the point of contact.

<u>Classification</u>	<u>Reaction of specimen</u>
V0	Extinguishes within 5 seconds and the cotton beneath does not ignite.
V1	Extinguishes within 25 seconds and the cotton beneath does not ignite
V2	Extinguishes within 25 seconds and the cotton beneath ignites.
HB	Does not extinguish within 25 seconds, and when testing the specimen horizontally, burns at a speed lower than 38 mm/min. (at a thickness greater than 3mm) and less than 76 mm/min (at a thickness of up to 3mm).

Values for Products: HB V2 V1 V0

### Testing for resistance to tracking (in compliance with IEC 112 publication):

The surfaces of the insulated item being tested are arranged horizontally, and two platinum electrodes are placed on them at a distance of 4 mm which are connected to a 50 Hz supply source.

electrodes before 50 drops have fallen. Obviously, the results depend on the level of voltage applied to the electrodes, and this is taken as the index of resistance to tracking.

Every 30 seconds a drop of 0.1% ammonium chloride in distilled water falls between the two electrodes. The test is passed if there are no electrical charges between the two

All plugs and connectors comply with the tracking resistance requirement of IEC.

# EPIC® Pin & Sleeve Connectors

## Technical Data: Switched Outlet Reference Data

### Reference Standards:

- **Socket-Outlets:** • CEI EN 60309-1 • IEC 309-1 • CEI 23-12/1 • CEI EN 60309-2 • IEC 309-2 • CEI 23-12/2
- Enclosures: • CEI EN 60529 • IEC 529 • CEI 70-1
- Safety Transformer: • CEI EN 60742 • IEC 742 • CEI 96-2
- Switches: • CEI EN 60947-3 • IEC 947-3 • CEI 17-11

### Constructional Characteristics of Socket-Outlets with Mechanical Interlock:

- Socket Outlets which are interlocked, both mechanically and electrically, make it possible to create electricity distribution systems in maximum safety, as well as meeting specific requirements of systems regulations for special system configurations, as described in the following:
  - According to CEI 64-8/7, sect 752.55.1- in electrical systems for public entertainment places "socket outlets with a power load over 16A must be the interlocking type."
  - According to CEI 64-2, chap. XII, sect. 3, para. 12.3.03- "socket-outlet": in making an operating safety system (AD-FT), "in C2 sites the socket outlets must be of the interlocking type."
- The interlock device prevents the switch from being closed if the plug has not been inserted in the socket-outlets and there after, stops it from being taken out if the switch is in the "closed" position. In addition, to this safety feature, the switch knob is connected to a "door lock" which only allows the enclosure to be opened for maintenance purposes if the switch is in the "open" position
- The complete functional unit is assembled onto the light alloy frame which is, in turn, coupled to the thermoset plastic enclosure: the entire functional structure thus makes up a "rigid" sub-assembly which is mechanically "defined", guaranteeing that the regulations and original functions are maintained in the long term;
- The parts making up the mechanical interlocking device are made in tropicalized steel plate, which guarantees the necessary rigidity and strength even if "forced through wrong use"
- The fuse-holder bases, where included, are in thermoset plastic (ULYSSE) or (ALUPRES) ceramic mounted and wired in the switched outlet. Unless specifically requested, the fuses are not normally included with the equipment;
- The interlocked socket outlets are available in the following forms:
  - with rotary control switch and fuse-holder base;
  - with rotary control switch, without fuse-holder base;

### Constructional Characteristics of Enclosures and Housings of ULYSSE Interlocked Socket-Outlets in Thermoset Plastic:

- Bottom boxes and covers are made of very thick reinforced thermoset plastic (SMC or CMC or BMC, according to use), with excellent dimensional stability, non-deformability and resistance to extremes of heat and to fire, to the action of chemical and atmospheric agents and to mechanical stress even at very low temperatures. All these characteristics in the material used for the enclosures ensures maximum performance in any environment, even when chemically aggressive, and represents perfection in terms of insulating material.
- The transparent covers are made of thick polycarbonate with a long- chain molecular structure; they are self-extinguishing and U.V. Stabilized for maximum resistance to atmospheric and chemical agents.
- Captive screws for closing the covers are made of stainless steel, with gaskets in non-aging elastomer;
- All the enclosures in this series are suitable for creating systems in compliance with standards CEI 64-8, and particularly for installation in places at "greater risk in case of fire" (64-8/7 sect 751); they also permit the fitting out of distribution boards with protection through complete insulation (standard CEI EN 60439-1) and meet the requirements of the IEC 670 publication.
- The entire series is completely modular and ideal for making even complex distribution boards using predefined configurations and standard accessories.

### Constructional Characteristics of Enclosures and Housings of ALUPRES Interlocked Socket-Outlets in Light Alloy:

- Bottom boxes and covers are made of UNI-5076 light alloy with a high aluminum content, oven painted internally and externally over a pretreatment of chromate galvanizing for a maximum resistance to corrosion. The heavy thickness of the material used for making these enclosures assures maximum results in any environment, even when chemically aggressive, and represents perfection in terms of metal structures thanks to the very high impact resistance;
- Captive screws for closing the covers are made of stainless or tropicalized steel, with gaskets in non-aging elastomer;
- Internal and external earth connection screws;
- All the enclosures in this series are suitable for creating systems in compliance with standards CEI 64/8, and particularly for installation in places with "greater risk in case of fire" (64-8/7 sect. 751);
- The entire series is completely modular and ideal for making even complex distribution boards using predefined configurations and standard accessories.

# EPIC® Pin & Sleeve Connectors

Circuit Wiring Diagrams- Configurations shown reference North American female devices from mating side

125V; 1+N+PE, 3-wire, 4h

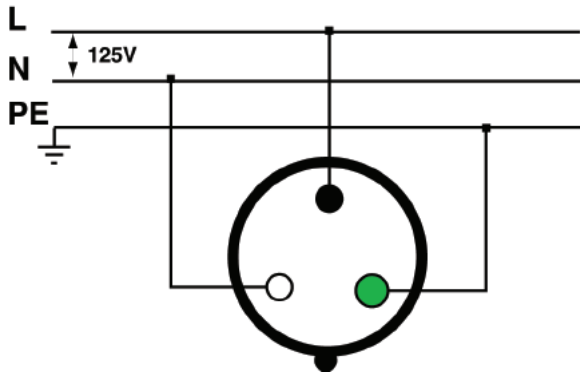

250V; 2+PE, 3-wire, 6h

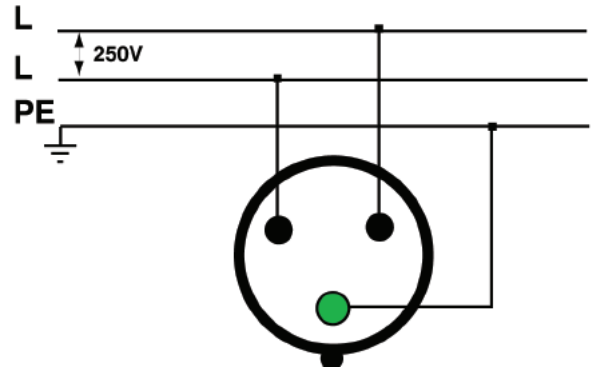

480V; 3+PE, 4-wire, 7h, 3phase

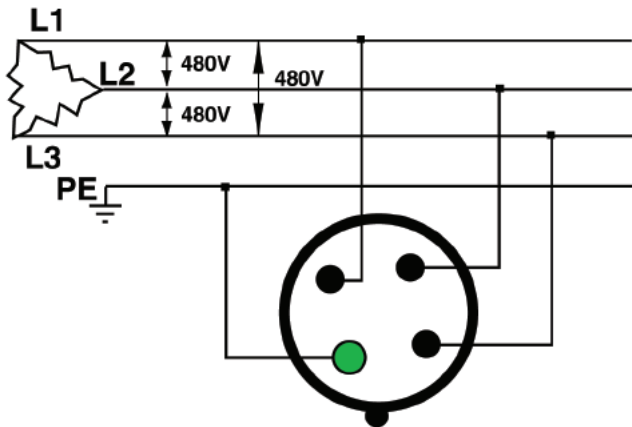

250VDC; 2+PE, 3-wire, 3h

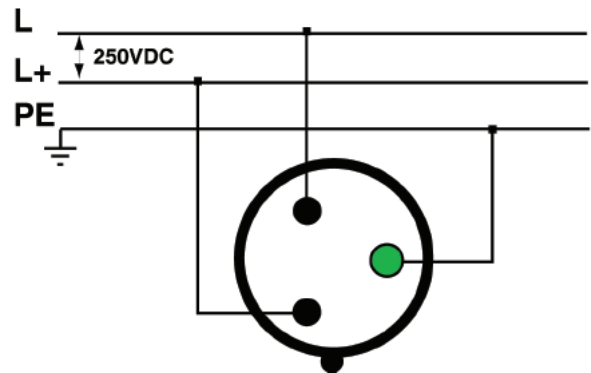

125/250V; 2+N+PE, 4-wire, 12h

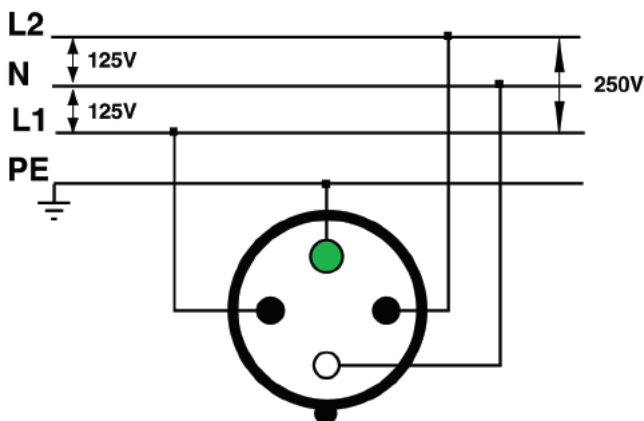

250V; 3+PE, 4-wire, 9h, 3phase

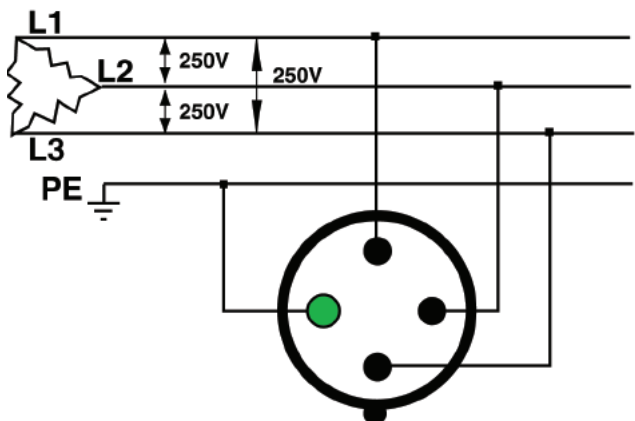

# EPIC® Pin & Sleeve Connectors

Circuit Wiring Diagrams- Configurations shown reference North American female devices from mating side

480V; 3+PE, 4-wire, 7h, 3phase

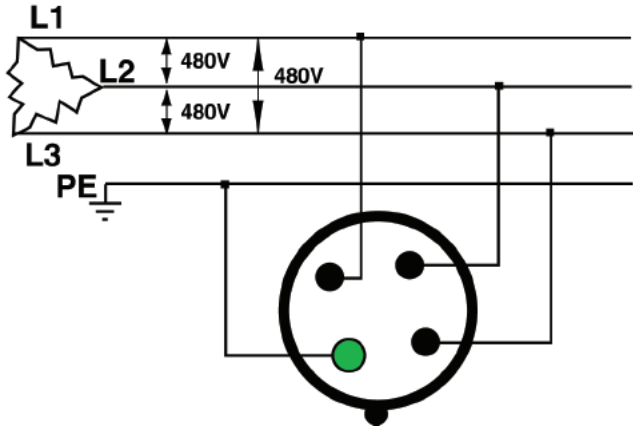

600V; 3+PE, 4-wire, 5h, 3phase

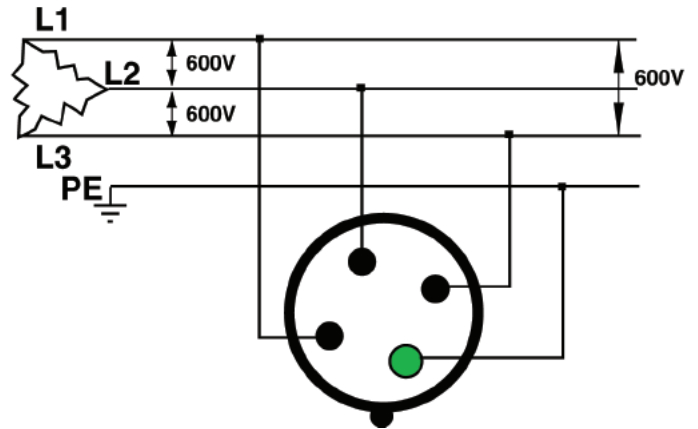

120/208V; 3+N+PE, 5-wire, 9h, 3phY

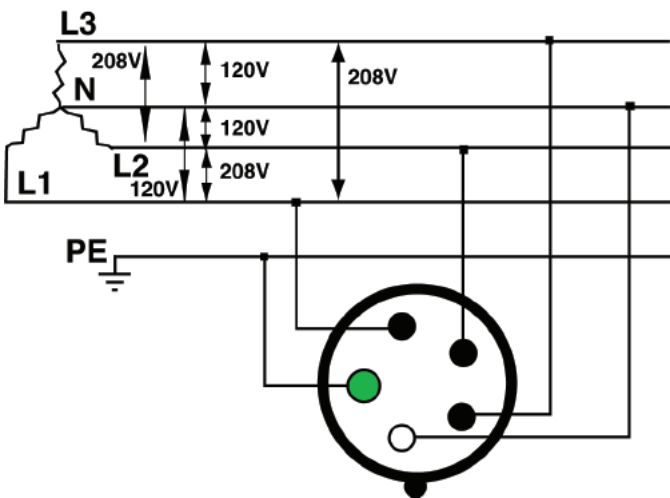

277/480V; 3+N+PE, 5-wire, 7h, 3phY

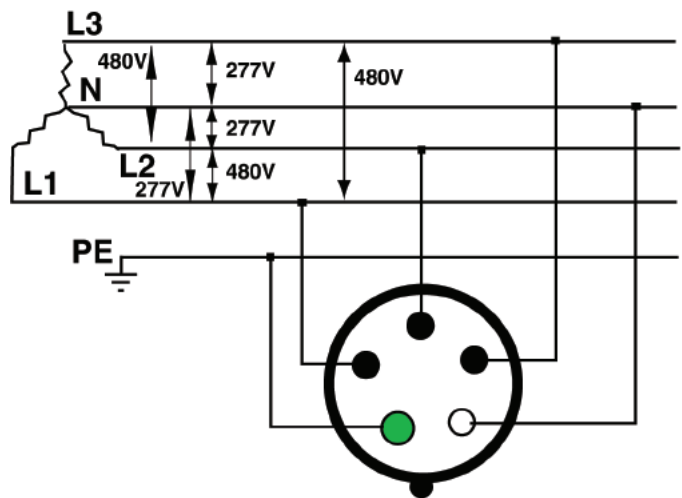

347/600V; 3+N+PE, 5-wire, 5h, 3phY

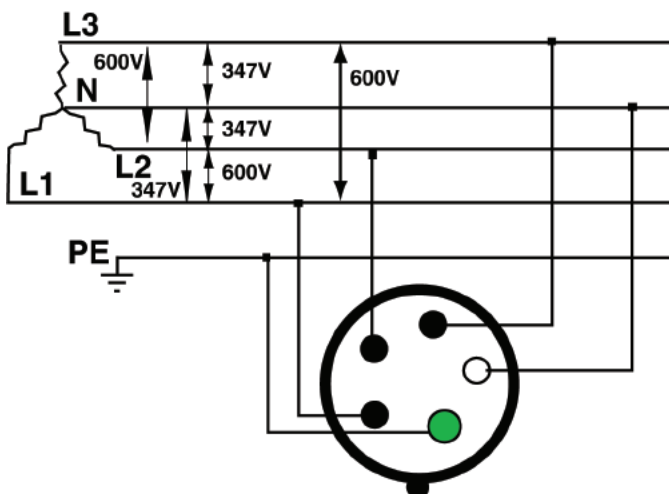

50-250V (400Hz); 3+N+PE, 5-wire, 2h

